



**YOUR MUSIC.  
REDISCOVERED.  
RELIVED. RELOVED.**

# ROBERTS

## S300

**Wireless stereo CD speaker system with FM / DAB / DAB+ / Internet Radio / Multi-room**  
and remote control from iPhone and Android using UNDOCK



**Please read this manual before use**

# Contents

<b>Introduction</b> .....	<b>1-9</b>	Stereo / Mono switching .....	48
Before you can use this product .....	2	Presetting stations in DAB and FM modes.....	49-50
About this instruction manual.....	3-4	<b>Music Player mode</b> .....	<b>51-64</b>
Controls and connections.....	5-9	Use with Windows, Apple Mac, Linux.....	51
<b>Configuration</b> .....	<b>10-21</b>	Accessing your audio files via UPnP using Windows 7, 8 & 10....	52-53
Plugging in and language selection.....	10-11	Locating and playing media files using UPnP .....	54-57
Clock and time settings .....	12	Display modes .....	58
Connecting to your computer network.....	13-17	Playlists .....	59-61
Download the UNDOK app.....	18	Prune servers .....	62
Setup new audio system - Apple iOS device.....	19	Windows 'Play To' / 'Cast to Device' function (UPnP renderer) ...	63-64
Setup new audio system - Android device.....	20	<b>Spotify Connect</b> .....	<b>65-68</b>
Network remote control options.....	21	Spotify Connect - the basics.....	65
Using an Ethernet connection .....	21	Set up a Spotify account.....	65
<b>Internet Radio mode</b> .....	<b>22-35</b>	Playing music using Spotify Connect .....	66
Internet Radio - the basics.....	22	Controlling Spotify on your sound system .....	67
Selecting a radio station by location and genre.....	23-25	Display modes - Spotify Connect .....	68
Searching for a radio station by name.....	26	<b>Bluetooth mode</b> .....	<b>69-72</b>
Selecting a new or popular station .....	27	Bluetooth mode .....	69
Selecting a podcast .....	28	Connecting Bluetooth devices.....	69
Presetting stations.....	29-30	Playing audio files in Bluetooth mode.....	70
Display modes.....	31	Connecting and reconnecting a Bluetooth device.....	71
Customising your station list.....	32-35	Bluetooth information.....	72
<b>DAB mode</b> .....	<b>36-43</b>	<b>CD / MP3 / WMA</b> .....	<b>73-81</b>
Selecting a DAB radio station.....	37	Compact discs .....	73
Display modes.....	38	Playing a CD.....	74-76
Finding new DAB radio stations .....	39	CD track programming .....	77
Manual Tuning.....	40	CD / MP3 / WMA mode .....	78-81
Dynamic Range Control settings .....	41	<b>SD / USB playback and recording</b> .....	<b>82-89</b>
Station order setup.....	42	Using SD cards and USB memory devices .....	82
Prune stations.....	43	SD / USB file and folder selection .....	83-84
<b>FM mode</b> .....	<b>44-50</b>	Recording to SD / USB.....	85-87
Manual tuning.....	45	Deleting files .....	88-89
Display modes.....	46		
Scan setting.....	47		

# Contents

<b>Clock and Alarms</b> .....	<b>90-98</b>
Automatically updating the clock .....	90
Setting the clock format .....	91
Manually setting the clock .....	92-93
Setting the alarm clock .....	94-96
Snooze timer .....	97
Disabling alarms .....	97
Sleep timer .....	98
<b>Multi-room and UNDOK</b> .....	<b>99-109</b>
Multi-room the basics .....	99
Creating and editing a multi-room group with UNDOK .....	100
Playing audio to a group .....	101
Volume control using UNDOK .....	101
Display and Controls in a multi-room configuration .....	102
View the sound system's multi-room details .....	103
Create a new multi-room group .....	104
Add products to the current group .....	105
Remove products from a current group .....	106
Leave a group .....	107
Dissolve a group .....	108
Alarms and multi-room .....	108
UNDOK Settings .....	109
<b>Display and Audio</b> .....	<b>110-115</b>
Equaliser function .....	110-111
Subwoofer control .....	112
Mute function .....	112
Brightness control .....	113
Auxiliary input socket .....	114
Headphone socket and Line out socket .....	114
Inactive Standby feature .....	115
Optical S/PDIF output socket .....	115
Aerial removal .....	115

<b>Information</b> .....	<b>116-128</b>
Factory reset .....	116
Software update .....	117
Network profiles .....	118
Clear network settings .....	119
Manual network configuration .....	120
Software version display and Audio FAQ .....	121
Troubleshooting .....	122-123
Audio codecs .....	124
Cautions and Specifications .....	125-126
Mains supply .....	127
Software License Information .....	128
Guarantee .....	Back page

## S300 Sound System features

The Roberts S300 sound system provides the following features:-

- Listen to local, regional, national and international broadcasts using FM, DAB and Internet radio and listen to over 1000 radio stations from around the country, and over 10,000 from around the world without using your PC.
- Listen to podcasts from a wide range of broadcasters.
- 30 radio station presets (10 Internet Radio, 10 DAB and 10 FM).
- Use the Music Player to play your music collection from devices on your network. Connection to Apple and Linux based computers is also possible.
- Plays MP3, WMA, AAC, FLAC, ALAC (Apple Lossless) and WAV formats via DLNA.
- Play from CD\*, USB memory and SD cards (including MP3 and WMA files).
- Record CD or radio to USB memory and SD cards.
- The S300 connects to your home computer network, either using WiFi or via a wired Ethernet connection. WiFi Protected Setup (WPS) is supported for simpler setting up with compatible wireless routers. Dual-band WiFi allows compatibility with a wide range of networks.
- Works with Windows 'Play to' / 'Cast to Device' function (as a Digital Media Renderer).
- Spotify Connect, allows your Spotify selections to be played through the sound system, remotely controlled from your iPhone, iPad, Android device or any Desktop.
- Supports remote control from Apple iPhone, iPad and Android using the UNDOK app.
- Your sound system may be connected as part of a wireless Multi-room system to allow whatever source is selected to be heard through other connected products.
- Bluetooth streaming to play your music or video soundtracks from your smartphone, tablet or similar device.
- All radio station presets, network configuration details and user settings are retained in the event of a power failure.
- Large clock display with time and date when in Standby.
- Two alarm timers with snooze feature to wake you to radio, CD, USB, SD card or buzzer alarm.
- Adjustable sleep timer, can be set to turn the sound system off after a delay of between 15 and 90 minutes.
- Easy-to-read colour graphic display with an adjustable display backlight.
- Auxiliary input for playing audio from MP3 players, iPods or other audio equipment.
- Line output socket for connecting the audio signal to an external amplifier or recorder and a stereo headphone socket for private listening.
- An acoustically tuned hand finished cabinet that includes bass ports and internal bracing for optimal sound reproduction.

### Note:

- \* 8cm (mini) CDs cannot be played. Transparent or partly transparent CDs cannot be played. Unusually thin (Eco) CDs cannot be played. Some copy-protected CDs may not be playable.

## Before you can use this product

Before you can use your sound system, you must have the following:

- A broadband Internet connection.
- A router (or equivalent wireless access point) providing a WiFi signal or Ethernet connection, connected to your broadband Internet Service Provider. The broadband modem, router and wireless access point will often be a single combined unit supplied by your Internet Service Provider or bought from a computer store.
- A smartphone or tablet which uses either the Android operating system (version 4.0.3 or later) or Apple iOS (version 8 or later).
- If your wireless network requires a security password to allow connection, then you either need to know the WEP, WPA or WPA2 key used for encryption so that you can get the sound system to communicate with the network, or your router needs to offer WiFi Protected Setup (WPS).
- If you choose to connect the sound system to your network using a wired Ethernet connection, then an Ethernet cable of appropriate length will be needed. If it is intended to listen to FM radio extensively, then there may be benefit in using a shielded Ethernet cable since this may reduce possible interference to the radio.

The sound system is compatible with 802.11b, g, n or a networks and can use 2.4 GHz or 5 GHz WiFi frequency bands.

If connecting using WiFi, the sound system will typically work within a 10-20 metre radius from your wireless router or access point. The actual range achieved will depend upon the building type, other nearby wireless networks, and possible interference sources. DAB and FM radio functions can operate wherever the sound system is able to receive a suitable broadcast signal.

**IMPORTANT:** Before you continue, make sure that your router (or access point) is powered up and working with your broadband Internet service (use your computer, smart-phone or tablet to verify this). To get this part of the system working you must refer to the instructions supplied with those items.

## About this instruction manual

This instruction manual is split into sections for each of the operating modes of your Roberts S300 sound system. Each section is clearly identified by the shaded heading in the top right hand corner of each pair of pages.

Before using the Internet Radio and Music Player functions, you will need to connect your sound system to your computer network using either the WiFi or Ethernet connection. This is covered in the section titled **Configuration**. This section also explains how to set the menu language option.

The **Internet Radio** section describes how to find radio stations to listen to. These can be radio stations that you already know and listen to conventionally, or new stations you may search for. You may set up stations that you like as Favourites so that they are more readily accessible.

The two sections for **DAB** and **FM Radio** describe how to use the sound system to listen to conventional radio broadcasts.

The section for the **Music Player** describes how you may play music files that you may have stored on a computer connected to your network. The use of Shared Media (using UPnP).

The **Spotify Connect** section explains the use of the sound system in conjunction with the Spotify internet based music streaming service.

The **Bluetooth** section describes how to use your S300 to play audio files or video soundtracks directly from your smartphone, tablet or similar devices.

**Configuration**

(page 10)

**Internet Radio**

(page 22)

**DAB Radio**

(page 36)

**FM Radio**

(page 44)

**Music Player**

(page 51)

**Spotify Connect**

(page 65)

**Bluetooth**

(page 69)

## About this instruction manual cont.

The section for **CD / MP3 / WMA player** describes how to play digital audio CDs or MP3 / WMA files which have previously been recorded to CD-R or CD-RW.

The section for **SD/USB media** describes playback and recording using SD card and USB memory devices.

The section titled **Clock and Alarms** describes the different ways by which the clock in the sound system may be set, as well as explaining the use of the alarms, snooze and sleep timer features.

The **Multi-room** and the **UNDOK** section explains how your sound system may be connected as part of a wireless music system.

The **Display** and **Audio** section shows how to adjust the display, use the equaliser and connect your sound system to other audio equipment.

The **Information** section includes troubleshooting, specifications and warranty information.

## Introduction

**CD / MP3 / WMA**

(page 73)

**SD / USB**

(page 82)

**Clock and Alarms**

(page 90)

**Multi-room & UNDOK**

(page 99)

**Display and Audio**

(page 110)

**Information**

(page 116)

## Controls and connections

### Top view

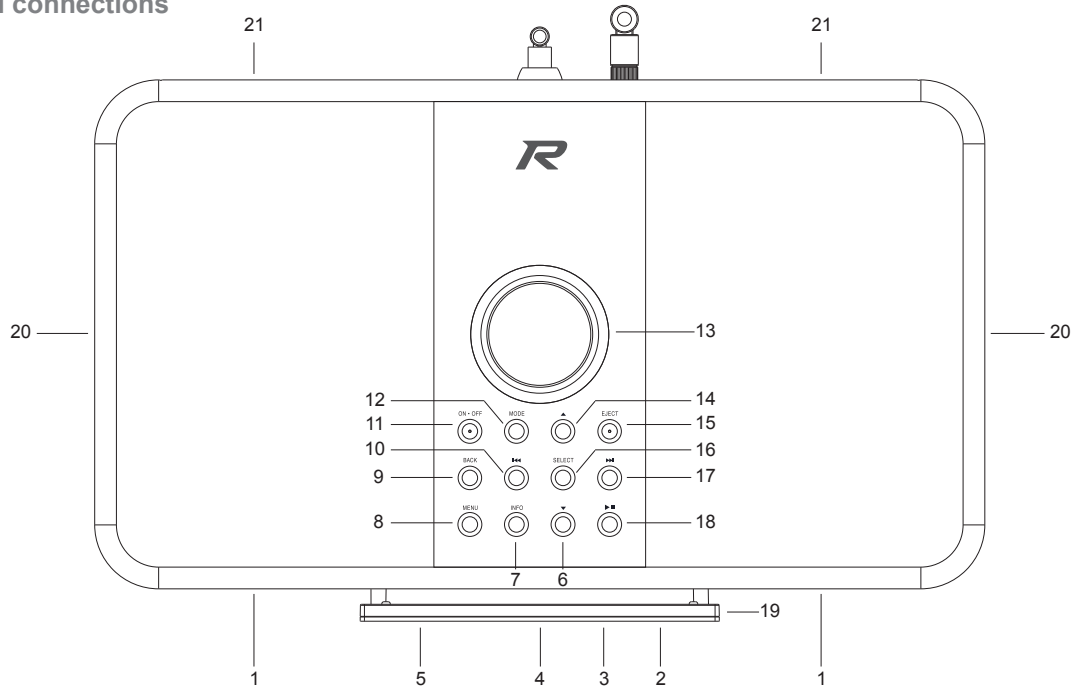

1. Treble / Mid-range speaker x 2
2. NFC detection area
3. Display panel
4. CD slot
5. Remote control sensor
6. Folder Down button
7. Info button

8. Menu button
9. Back / Bluetooth Pair button
10. Menu Down / Previous button
11. On / Standby button
12. Mode button
14. Folder Up button

15. CD Eject button
16. Select / Stop / Preset button
17. Menu Up / Next button
18. Play / Pause button
19. SD card slot
20. Passive Bass radiator x 2
21. Bass speaker x 2



Rear view

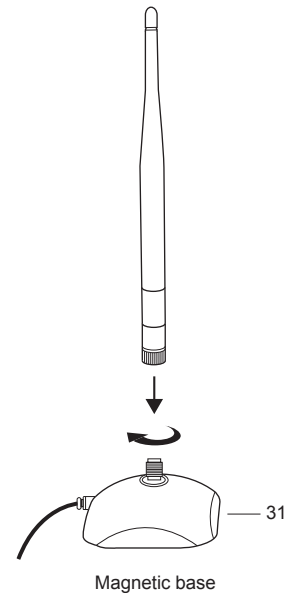
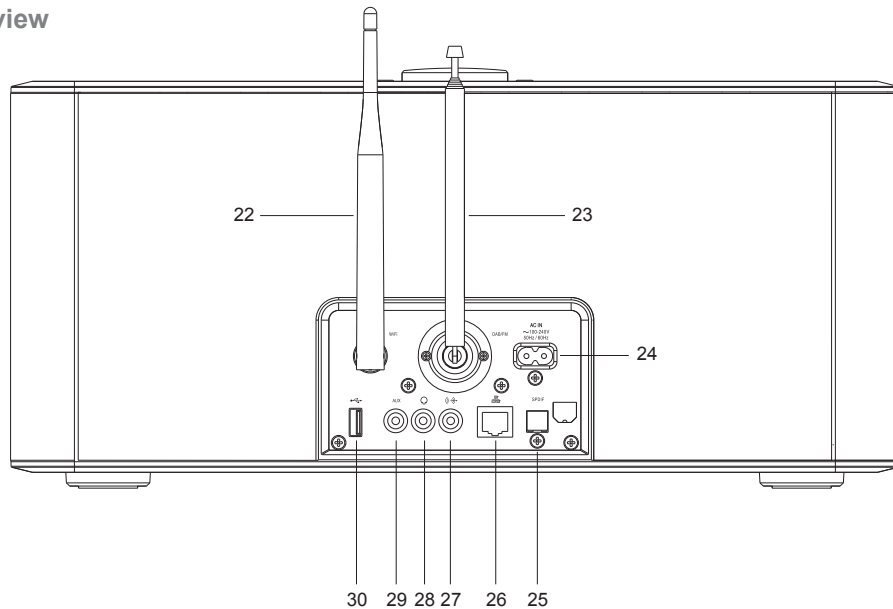

- 22. WiFi antenna (removable see item 31)
- 23. Telescopic aerial for DAB and FM (antenna cable socket behind)
- 24. Mains input socket
- 25. Optical output socket (Toslink)
- 26. Ethernet socket (RJ-45)
- 27. Line output socket

- 28. Headphone socket
- 29. Auxiliary input socket
- 30. USB playback socket
- 31. WiFi antenna base (this allows the WiFi antenna to be placed away from the unit to improve reliability of the WiFi connection)

## Controls and connections - cont.

### Remote control handset

- |                                      |                                |
|--------------------------------------|--------------------------------|
| 1. Sleep / Clock Set button          | 14. Mute button                |
| 2. Infra-red LED                     | 15. Subwoofer Up / Down button |
| 3. Alarm button                      | 16. Key pad buttons 1-10/0     |
| 4. On / Standby button               | 17. Repeat button              |
| 5. Dimmer button                     | 18. Random button              |
| 6. Media button                      | 19. Volume Up / Down button    |
| 7. Radio button                      | 20. Play / Pause button        |
| 8. Auto Tune / Program tracks button | 21. Menu Right / Next button   |
| 9. Menu Up / Folder Up button        | 22. Info / Menu button         |
| 10. Select / Stop / Preset button    | 23. Record button              |
| 11. Menu Left / Previous button      | 24. EQ button                  |
| 12. Menu Down / Folder Down button   | 25. CD Eject button            |
| 13. Back / Bluetooth Pair button     |                                |

### Remote control functions

Most of the functions of the S300 sound system can be controlled using either the product or the remote control. However, there are a few functions which are more easily accessible using the remote control. These are:

Radio station presets  
 CD track access by numbers  
 Audio mute  
 CD, SD, USB track programming

DAB / FM auto-tune  
 Random function  
 Repeat function

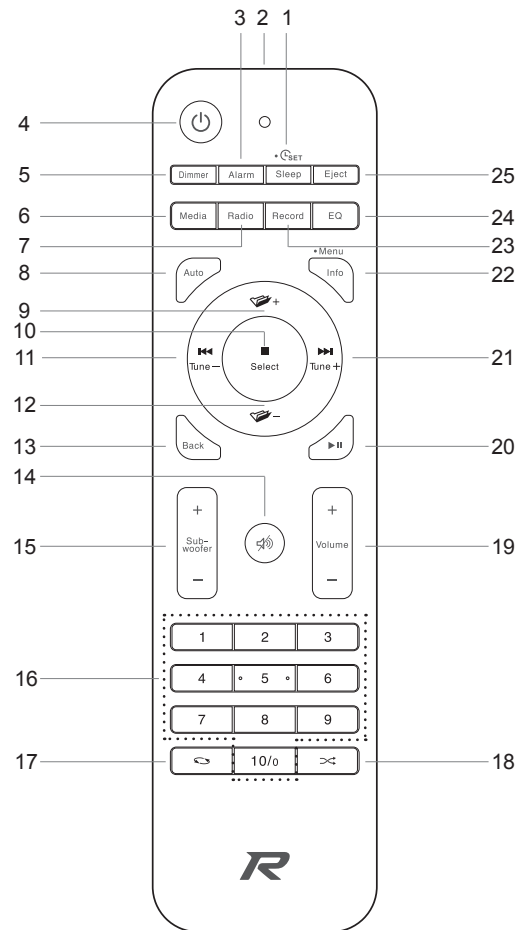

## Remote control battery replacement

1. Slide out the battery holder as shown.
2. Gently remove the batteries from the holder.
3. Insert 2 x CR2032 size batteries into the compartment with the positive side of the batteries (marked +) facing upwards with the holder positioned as shown.

**Note:** The remote control uses CR2032 batteries. For optimum battery life, fit batteries in locations A and B. The control can also be used with a single battery installed in location A but the battery life will be reduced. The control will not work if there is only a single battery installed in location B.

4. Replace the battery holder as shown and ensure that the battery holder clicks into place.
5. If the remote is not to be used for an extended period of time it is recommended that the batteries are removed.

**IMPORTANT:** The batteries should not be exposed to excessive heat such as sunshine, fire or the like. After use, disposable batteries should if possible be taken to a suitable recycling centre. On no account should batteries be disposed of by incineration.



### WARNING:

- Do not ingest the battery. Chemical Burn hazard.
- The remote control supplied with this product contains a coin/button cell battery. If the coin/button cell battery is swallowed it can cause severe internal burns in just 2 hours and can be fatal.
- Keep new and used batteries away from children. They can be a choking hazard.
- If the battery compartment does not close securely, stop using the product and keep it away from children.
- If you think batteries might have been swallowed or placed inside any part of the body, seek immediate medical attention.

### CAUTION

Danger of explosion if the battery is incorrectly replaced. Replace only with the same or equivalent type.

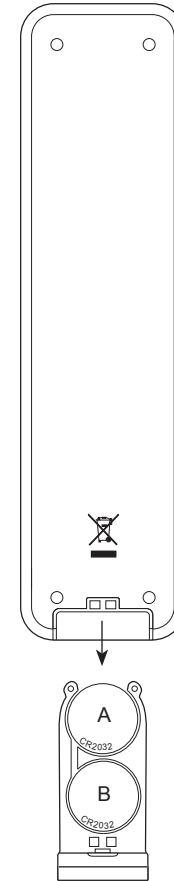

## Navigation controls

This page describes the basic means of controlling your S300 sound system. Instructions for each operating mode are given in the later sections of this book.

1. Pressing the **On/Standby** button brings your sound system out of Standby mode. Pressing **On/Standby** while the sound system is in use will cause it to return to the Standby mode with the clock display.
2. Pressing the **Radio** button gives you access to each of the operating modes in turn: Internet Radio, Spotify, DAB radio, FM radio and Auxiliary Input.
3. Pressing the **Media** button gives you access to each of the operating modes in turn: CD, USB memory device, SD card, Bluetooth and Music player.
4. Alternatively, press the **Mode** button on the sound system to select the desired operating mode.
5. Pressing and holding the **Info/Menu** button (on the remote control) or press and release the **Menu** button (on the sound system) will access the menu system. The **Info** button also allows the display of information relating to the radio station or music file being played.
6. Many operations require the user to make a selection from the menu. Highlight the menu item using the **Menu Up**, **Down** or **Left** and **Right** buttons. Press and release the **Select** button to select that item. If there are more than six items in a menu, then the display will automatically scroll up or down so that the additional items become visible. A sliding bar on the right will give an indication showing the current portion of the menu that is displayed.  
If there are many items in a menu, then the sound system allows the menu to 'wrap around' in either direction. This can make it easier to reach items at the end of a long menu, such as a list of countries or Internet radio stations.
7. If an error is made when navigating the menus, it is generally possible to go back to a higher level menu by pressing the **Back** button.

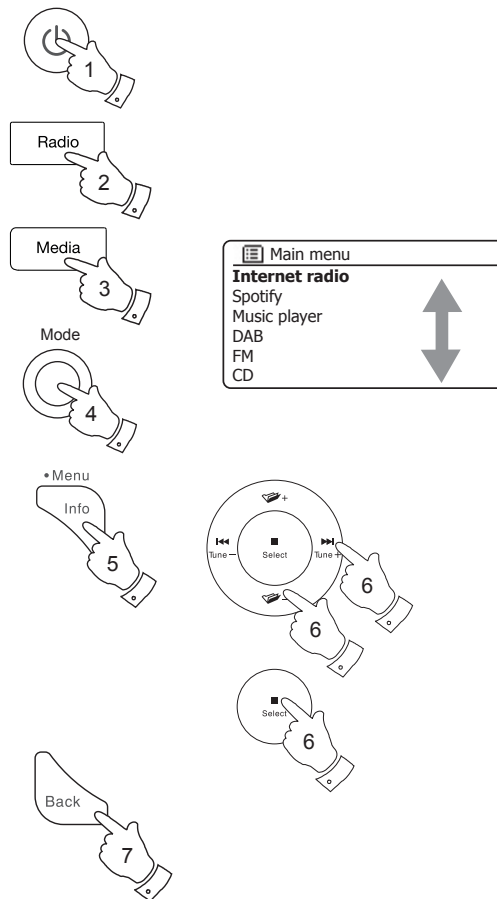

## Plugging in and language selection

Your sound system may be configured using either the display and buttons on the product, or by using the UNDOK app.

1. Place your sound system on a flat surface and plug the mains lead into the **mains socket** located at the rear of your sound system ensuring that the plug is pushed fully into the socket.
2. If you wish to use a wired network connection, plug the Ethernet cable into the RJ-45 socket at the back of the sound system.
3. Plug the other end of the mains lead into a wall socket and switch on the wall socket.

**IMPORTANT:** The mains plug is used as the means of connecting the sound system to the mains supply. The mains socket and any multi-way mains block used for the sound system must remain accessible during normal use. In order to disconnect the sound system from the mains, the mains plug should be removed from the mains socket completely.

4. When you apply power, the display on the sound system will light up and say: 'R-Line by Roberts.' If this is the first time that you use your sound system (or after a Factory Reset) the display will show 'Setup wizard' and 'YES' will be highlighted on the screen.

**Note:** If you wish to use UNDOK to setup your sound system, please see page 18.

5. By default your sound system will display all menus and messages in English. If English is your preferred language then press the **Select** button to select 'YES' and to begin setting up your sound system. If you selected 'YES' please skip to step 1 on page 12.
6. If your preferred language is not English, press the **Menu Up or Down** buttons so that the 'NO' option is highlighted. Press the **Select** button to enter the selection. Continue on the next page.

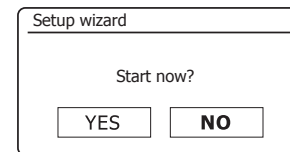
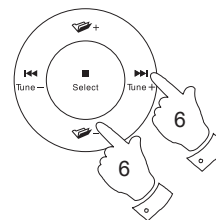
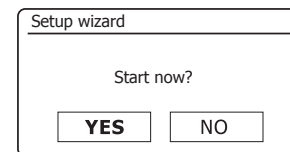
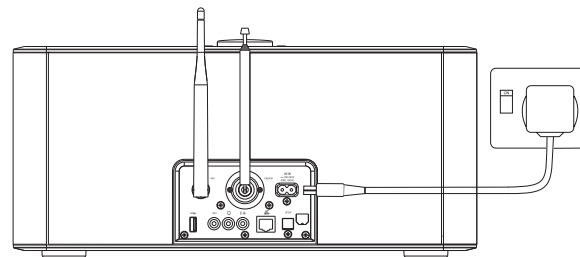

## Plugging in and language selection - cont.

7. Your sound system will ask whether the Setup Wizard should be run at the next start up. Although the 'YES' option is highlighted if you wish to change the language you will need to select the 'NO' option.

Press the **Menu Up** or **Down** buttons to highlight the 'NO' option. Press the **Select** button.

8. Your sound system will then display the Main menu. Press the **Menu Up** or **Down** buttons until 'System settings' is highlighted on the screen.

Press the **Select** button to enter the System Settings menu.

9. Press the **Menu Up** or **Down** buttons until 'Language' is highlighted on the screen. Press the **Select** button to enter the Language menu.

10. Press the **Menu Up** or **Down** buttons until the desired language is highlighted on the screen.

Press the **Select** button to select the chosen language option.

The display will then change to show the System Settings menu in the chosen language.

11. Press the **Menu Up** or **Down** buttons until the 'Setup wizard' option is highlighted on the screen and then press the **Select** button.

If you change the language you will not see 'Setup wizard' in English. You will see an equivalent menu item in your language - for example, 'Assistant réglages' in French, or 'Inställningsguide' in Swedish.

12. Press the **Menu Up** or **Down** buttons until 'YES' is highlighted on the screen and press the **Select** button to select it.

This will cause the sound system to run the set up procedure as if it had just been switched on for the first time, but it will do this using the language selected in step 10, above.

13. Continue setting up your sound system on the next page.

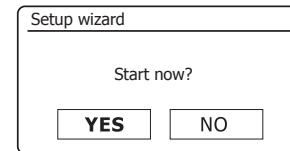
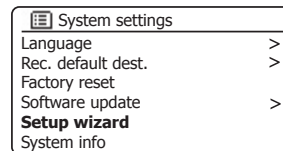
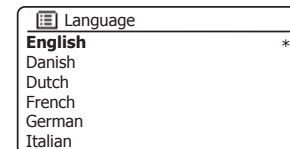
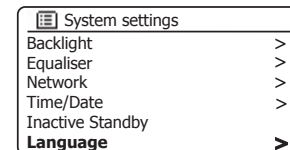
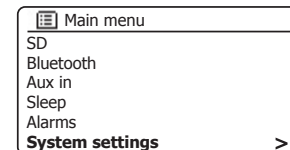
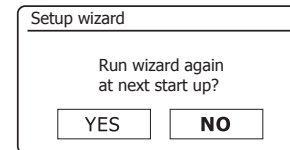
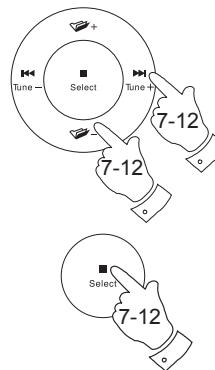

## Clock and time settings

The following instructions assume that you have either just plugged in your sound system (see page 10) or that you have just specified the language option for the menus (see page 11).

1. Press the **Menu Up** or **Down** buttons to highlight the desired clock format (either 12 or 24 hour) then press the **Select** button to enter your selection.
2. Next, the way in which the sound system updates its clock is set. A menu allowing you to specify the auto-update option for the clock will be shown. The 'Update from Network' option will be best for most users.
3. Press the **Menu Up** or **Down** buttons to choose an auto-update option for the clock. This can be updated from DAB or FM radio, from the Network, or not updated. The default is to auto-update from the network. If you choose another option go to 'Connecting to your computer network' on page 13. Otherwise you will first need to select the correct time zone and daylight savings setting, see the next steps. If you choose 'No update' you will need to set the clock manually later, see page 92. Press the **Select** button to confirm your choice.
4. Press the **Menu Up** or **Down** buttons to highlight the time zone for your current location. Press the **Select** button to enter the setting.
5. You will then need to set the Daylight Savings option according to your location (Daylight Savings is also known as Summer/Winter time or BST/GMT adjustment).  
Press the **Menu Up** or **Down** buttons to highlight 'ON' or 'OFF' as required. The asterisk shows the current setting. Press the **Select** button to enter the selection.  
In the UK, 'ON' is equivalent to British Summer Time and 'OFF' is equivalent to Greenwich Mean Time.
6. Continue setting up your sound system on the next page.

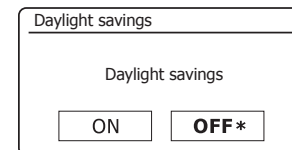
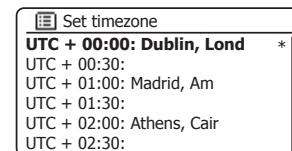
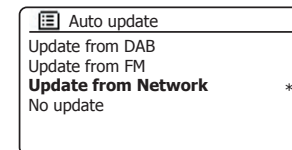
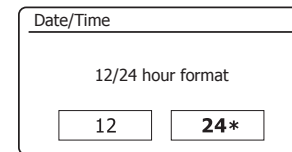
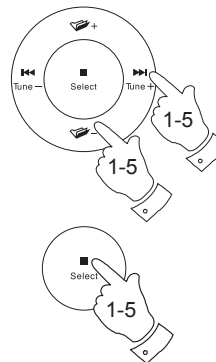

## Connecting to your computer network

Before you can use your S300 sound system to listen to Internet radio or to music streamed from your computer, it must first be connected to your computer network.

This section of this book describes how to connect the sound system to your network using either the wireless (WiFi) connection or the wired (Ethernet) connection.

The following instructions assume that you have just set up the clock and time options using the Setup Wizard as described on the preceding page.

These instructions also apply to the Network Wizard in the Network Settings menu (from step 2 onwards).

1. The display will show a list of regional options for the WiFi configuration.

Press the **Menu Up** or **Down** buttons to highlight the required region (for the UK choose *'Europe'*), and then press the **Select** button to make the selection. Do this even if you are planning to use the wired Ethernet connection. Your sound system will then scan for available WiFi networks.

2. The sound system will enter the Network Settings Wizard and will display *'Scanning...'*. The sound system will automatically scan both the 2.4GHz and 5GHz WiFi bands. After a short while the display will show a list of the available WiFi networks. If you are intending to use the WiFi connection, go to step 3 on the next page.

To use the Ethernet connection to your router (with automatic configuration), press the **Menu Up** or **Down** buttons to point to the *'[Wired]'* menu item. Press the **Select** button and the sound system will attempt to connect.

If your network allows automatic configuration (which is normal) the sound system will acquire a network address. The screen should say *'Connecting...'*, and then *'Setup wizard completed'*. Press the **Select** button to exit the setup wizard and show the Main menu. You can then skip to paragraph 10 on page 16.

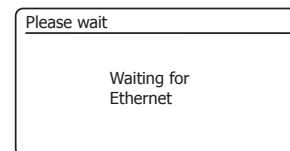
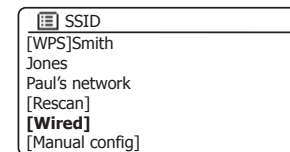
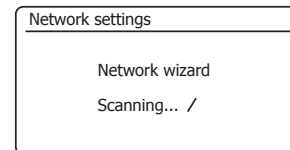
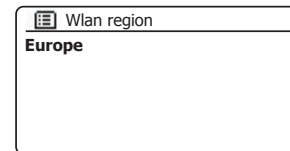



## Connecting to your computer network - cont.

There are two indicator lights incorporated into the RJ-45 connector. If you have problems with your wired connection, they may help you to identify the possible cause of the problem.

Green ON = Link established; OFF = no connection

Yellow Flashing = Data transfer

If your network does not support automatic configuration or if you wish to set it up manually then you should select *'Manual config'* instead of selecting *'Wired'* in the Network Wizard, then go to page 120.

3. If you plan to use a WiFi connection, you will first need to identify your network in the list of network names presented by the Network Wizard. If no networks are found then you may have to get your wireless router working (please see the instructions supplied with it) or you may be too far from the router.

When the sound system finds your wireless network, it displays the Network Name (SSID) for the wireless access point on the screen. This is a name that is allocated to the access point in your router by the person who set up the network - for example: *'Jones family'* or *'Paul's network'*. Routers supplied by Internet Service Providers often have the default name of the WiFi network provided on a label or card for easy reference (e.g. BTHub - 1234, virginmedia 1234567). If the router supports WiFi Protected Setup, then *'WPS'* will be shown in front of the SSID.

It is possible, and in some locations highly likely, that your sound system will find more than one wireless network, in which case you should choose which one you need to connect to.

4. Press the **Menu Up** or **Down** buttons to see the SSID for each wireless network that has been found. If your network is shown proceed to step 6 on the next page. If it is *not* shown then proceed to step 5, also on the next page.

If you make a mistake at any point, use the **Back** button to go back to the previous screen.

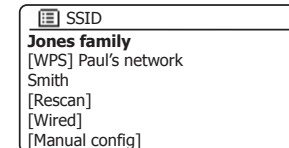
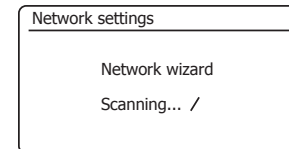
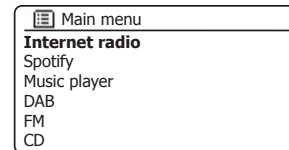
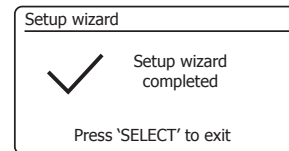
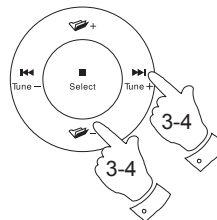

## Connecting to your computer network - cont.

- If your network is not found, it may be because the router is configured not to broadcast the SSID. You should then use the **Menu Up** or **Down** and **Select** buttons to highlight and select the *'[Manual config]'* option in order to enter the network details manually. This is described in 'Manual Network Configuration', see page 120.

If your network name is being broadcast, and it was not found, then try re-scanning (press the **Back** button), and if necessary try moving your sound system to a location closer to your access point / router.

- When the SSID for the wireless network you wish to connect to is highlighted on the screen, press the **Select** button. If WiFi Protected Setup (WPS) was indicated, you will see an additional menu at this point, otherwise proceed to step 7.

Choose one of the WPS menu options as required for your router (WPS may be via push button, or using an identification number).

*'Push Button'* - the display prompts you to press the WPS button on your router and then the **Select** button on the sound system. The two devices should then connect with the encryption key sent automatically to the sound system.

*'PIN'* - the display shows an identification number which you must enter into your router using a web browser (refer to your router's user documentation). You should then press the **Select** button on the sound system. The two devices should then connect with the encryption key sent automatically to the sound system.

*'Skip WPS'* - if you wish to enter the encryption key yourself (or if it was previously entered).

If you chose Push Button or PIN the screen will then show *'Connecting...'* and then *'Setup wizard completed'*. Press the **Select** button to exit the setup wizard and then go to paragraph 10 on the next page.

- If your network is configured without an encryption key, the screen should say *'Connecting...'*, and then *'Setup wizard completed'*. Press the **Select** button to exit the setup wizard and show the Main menu. If this is the case then you have successfully connected your sound system to your network, so please go to paragraph 10 on the next page.

- If the screen displays *'Key:'*, it is because the network is using one of the encryption systems: Wired Equivalent Privacy (WEP) or WiFi Protected Access (WPA). You will need to enter the correct WEP or WPA key into the sound system to allow it to communicate with your wireless network. If you do not have the WEP or WPA key, then you should obtain it from the person who set up your network. Some wireless routers may come with an encryption key already set up by the supplier, in which case you should refer to the documentation provided with it. WPA is used here to also include WPA2.

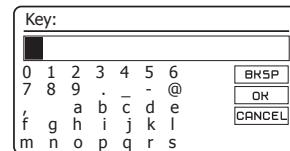
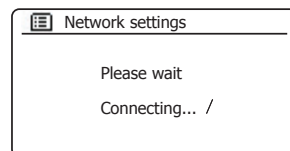
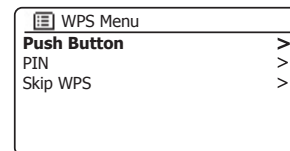
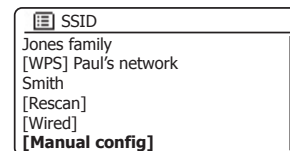
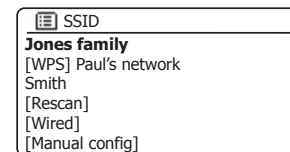

## Connecting to your computer network - cont.

## Configuration

WEP keys are 10 or 26 characters long (using 0 - 9, and A - F). Some wireless routers can also use pass-phrases for WEP but these are not supported by the unit. WPA keys are usually set up using a pass-phrase of between 8 and 63 characters. Your sound system accepts pass-phrases for WPA keys.

- To enter the WEP or WPA key, characters are selected and entered using the **Menu Up** or **Down, Left** or **Right** and **Select** buttons. The highlight scrolls through the available characters as well as the three controls on the right. The character currently highlighted will be entered when you press the **Select** button.

Do this as needed until the complete key has been entered. *Remember, WEP keys only use the numbers 0-9 and letters A-F. WPA keys are sensitive to upper and lower case characters. You must enter the key **exactly** or the sound system will not connect to the network.*

The three controls on the right-hand side of the screen have special functions. You can quickly access these by pressing the **Info** button and then using the **Menu Up** or **Down** and **Select** buttons as needed:

- select '[BKSP]' to erase a character just entered (long press to clear); **Info** again to continue
- select '[OK]' when the complete key has been entered
- select '[CANCEL]' to cancel and re-run the Network Wizard

If a WEP or WPA key has previously been entered for the selected SSID then the display will show 'Key: [Set]'. If you have previously entered a different key, you must clear this by selecting the '[BKSP]' symbol. This will remove the '[Set]' indication.

After the final character of the WEP or WPA key has been entered, highlight the '[OK]' symbol and press the **Select** button. The screen will show 'Connecting...' and then 'Setup wizard completed'. Press the **Select** button to the exit setup wizard. The sound system should now be able to connect to the network.

- Once you have connected your sound system to the network (and therefore also to the Internet) it will display the Main menu. Press the **On/Standby** button to put the sound system into Standby mode. It should then display the time as obtained from the Internet. If the time display is not correct for any reason, it can easily be adjusted later, see page 92, 'Manually setting the clock'.

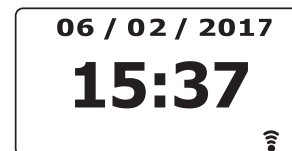
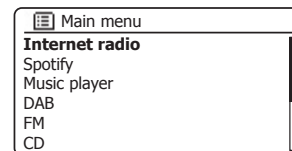
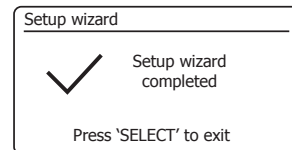
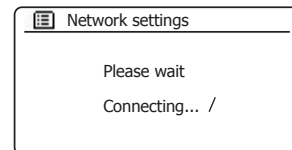
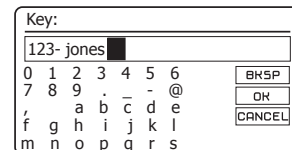
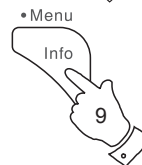
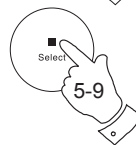
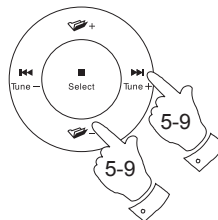

## Connecting to your computer network - cont.

If you have followed the steps on the preceding pages successfully, your sound system will have connected to your router, and then made a connection to the Internet and set its clock. If this is the case, then you can try listening to radio stations via the Internet as described on page 22 onwards.

## Changing the network connection

In the sections above, you chose how your sound system would be connected to your network, either using a WiFi connection or using a wired Ethernet cable. From time to time, you may find that you need to connect to different computer networks. The Network Settings menu allows you to change your sound system's network settings, scan for an alternative wireless network, or to manually configure the network parameters.

The steps outlined below describe how you can do this - see also the section 'Network profiles' on page 118. If you have no need to do this, however, please skip to page 22.

## Configuring the sound system to use an alternative WiFi connection

1. From the Network Settings menu select '*Network wizard*'. This will present you with details of any WiFi networks that are found. Scroll down the list using the **Menu Up or Down** buttons to the desired network name. Press the **Select** button to select this network.

The sound system will then use its WiFi system to communicate with the network. Depending on the settings for the new network you may need to enter an encryption key (see pages 15-16). By default the sound system will then acquire an IP address and other network settings from the network's router using DHCP (Dynamic Host Configuration Protocol).

## Configuring the sound system to use the wired Ethernet connection

2. Connect your sound system to your router using an Ethernet cable plugged into the RJ-45 socket at the back of the unit. From the Network Settings menu select '*Network wizard*'. This will display a list of any WiFi networks that are found. Scroll down the list and select the '*Wired*' option.

The sound system will then use its Ethernet connection to communicate with the network. By default the unit will then acquire an IP address and other network settings from the network's router using DHCP (Dynamic Host Configuration Protocol).

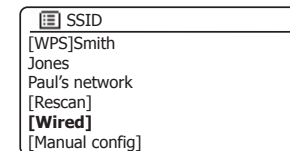
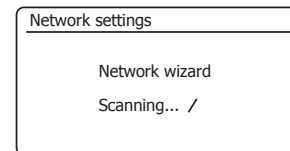
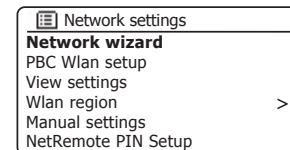
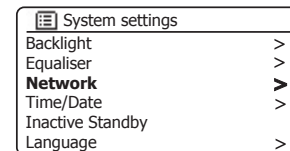
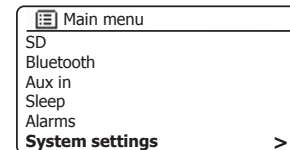

## Configuration - Using the UNDOK app

### Download the UNDOK app

Download and install the UNDOK app on to your Android or iOS device.



- iOS - Download from Apple App Store
- Android™ - Download from Google Play



- If you already have the UNDOK app installed on your device ensure that you have the latest version.
- It is possible that this app may have been changed slightly since these instructions were written.
- Please refer to the Roberts Radio website for guidance on how to use the latest version.

**Note:** At the time of writing Android version 4.0.3 and later or iOS version 8 or later are required to use UNDOK.

## Setup new audio system - Apple iOS device

If your device uses Android, please see page 20.

The **UNDOK app** has a setup wizard to help configure suitable audio devices to connect to your home WiFi network.

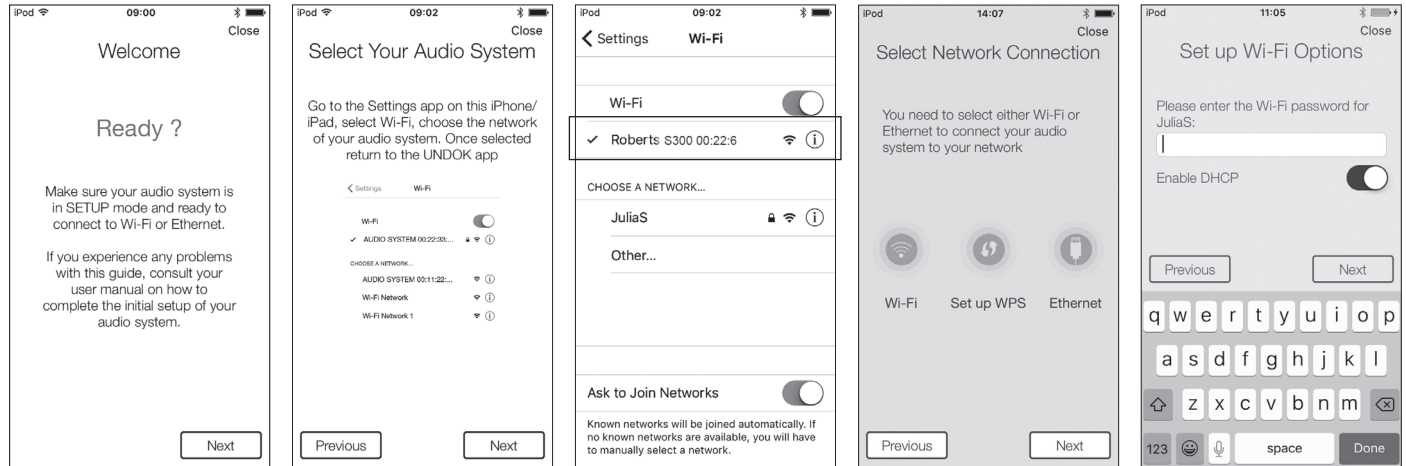

1. Open the **UNDOK app**.
2. Setup a **New Audio system**.
3. The app will prompt you to use your **device's WiFi** settings to connect to your sound system.
4. Select your **Roberts S300** sound system. Once your device has connected to the sound system, **return** to the UNDOK app.
5. Use the app to complete the setup, including giving the sound system a name (living room, etc), whether it is connected via WiFi or Ethernet. If you wish to connect using an Ethernet cable please (see page 21).
6. For a WiFi connection the app will ask you to choose a WiFi network and enter the appropriate password.
7. Your sound system will connect to your network.

## Setup new audio system - Android device

If your device is an iPhone or iPad (i.e. uses iOS) please see page 19.

The **UNDOK app** has a setup wizard to help configure suitable audio devices to connect to your home WiFi network.

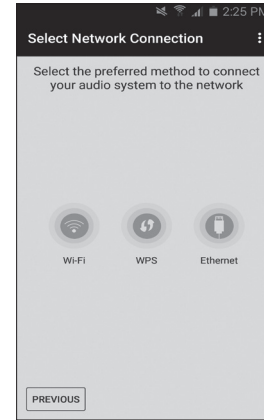
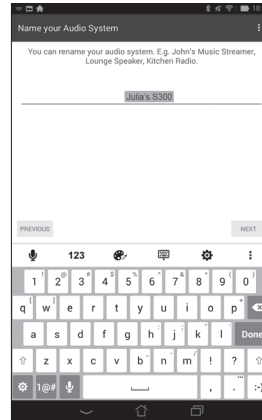
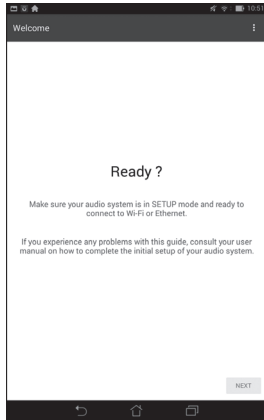

1. Open the **UNDOK app**.
2. Setup a **New Audio system**.
3. The app will show a list of suggested audio systems to setup.
4. Your sound system will normally appear in this list as **Roberts S300**. It may appear in the list below called Other. Select the sound system to be setup.
5. Use the app to complete the sound system setup, including giving the sound system a name (living room, etc).
6. Choose whether it is connected via WiFi or Ethernet. If you wish to connect using an Ethernet cable please (see page 21).
7. For a WiFi connection the app will ask you to choose a WiFi network and enter the appropriate password.
8. Your sound system will connect to your network.

**Note:** If when setting up your sound system your Android device complains that it cannot connect to the internet this is because it is temporarily connected directly to your sound system. You should ignore this warning message.

## Network remote control options

### Network PIN setup (PIN number)

Your sound system has the option of being controlled by an application installed on an Apple iPhone, iPod touch, iPad or equivalent Android device. The PIN number facility allows you to ensure that your sound system can only be controlled by your own device rather than someone else's.

The remote control application is called UNDOK, by Frontier Silicon Limited, and is available from the Apple App Store and Google Play for your device.

UNDOK will try to use the default PIN of '1234' to control your sound system.

You may change the PIN if desired using the '*NetRemote PIN Setup*' option in the *Network settings* menu. The updated PIN should then be used in the UNDOK app to allow the app to reconnect to the sound system. The app will prompt you for the PIN as needed.

### Using an Ethernet connection

If you choose to connect your sound system to the network using a wired Ethernet connection, then an Ethernet cable of the appropriate length will be needed (cable not supplied).

The app will offer you an option to connect using Ethernet during the setup procedure.

1. Connect the **Ethernet cable** to the RJ45 Ethernet socket on the back of your sound system.
2. Select the Ethernet option on the UNDOK app and follow the onscreen guide.

In situations where there are many WiFi networks in use, it is possible that multi-room performance of the product may be improved by using the ethernet connection.

If it is intended to listen to FM radio extensively, then there may be benefit in using a shielded Ethernet cable since this may reduce possible interference to the sound system.

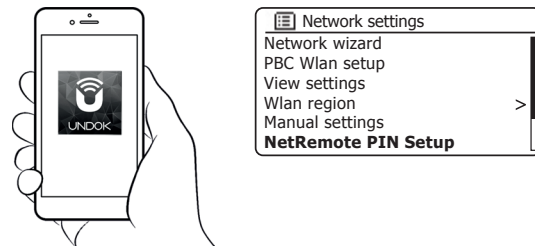

Control via the UNDOK app

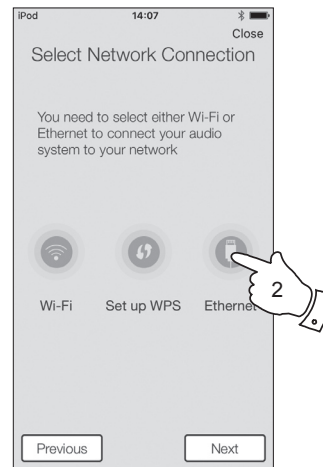



## Internet Radio

### Internet Radio - the basics

Before you can use your sound system to listen to broadcasts via the Internet, it is necessary to have connected it to your computer network using either the wireless (WiFi) connection or the wired Ethernet connection (RJ-45 socket) located on the back of the unit. Please see page 10 for details.

There are literally many thousands of radio broadcasts available via the Internet as well as 'Podcasts'. Your sound system provides several ways of searching for broadcasts in order to make finding and choosing them easier. Once you have found the radio stations that you like, you may either store them as presets within the sound system, or add them to a list of your favourite stations which your sound system can access. The number of presets is limited (there are ten presets on the radio) but you can store as many favourites as you like.

You may search for an Internet radio station by Location. If you know the name of the station and the country from which a station is broadcast this may be the easiest method to find a station. It is also a great way to experience radio from other parts of the world.

You may also search for an Internet radio station by Genre. If you prefer a particular type of music, Blues for example, you may search for a radio station that broadcasts that type of music, and you can choose from a list of Blues radio stations regardless of location, or taking location into account.

If you know part of the name of an Internet radio station, you can enter it into the sound system and it will search for stations that match that name. This can be helpful if you are unsure of the location or genre of a particular station.

The S300 sound system connects to a radio station database which serves many users in many countries. This means that there is a very wide range of programme content available. You can also search for stations which have been recently added to those available (new stations) or you can search for the most popular.



Internet radio

## Selecting a radio station by location

1. Press the **On/Standby** button to switch the sound system on. Then press and release the **Radio** button to select the Internet Radio mode display.
2. **Press and hold** the **Menu** button to enter the main Internet Radio menu. Press and release the **Menu Up** or **Down** buttons until 'Station list' is highlighted on the display and then press and release the **Select** button to select the option.
3. Press the **Menu Up** or **Down** buttons until 'Stations' is highlighted on the display and then press and release the **Select** button.  
Note that the menu may offer one or more local selections based upon the country in which the unit is being used, according to your internet IP address ('United Kingdom' and 'BBC' stations, for example).
4. Press the **Menu Up** or **Down** buttons until 'Location' is highlighted on the display and then press and release the **Select** button.
5. Press the **Menu Up** or **Down** buttons to scroll through the list of continents. When the desired continent is highlighted press and release the **Select** button to enter your selection.
6. The display will show a list of countries within the chosen continent. If there are many countries shown you can scroll through the list continually in either direction. For example, if the chosen continent was Europe, then to find the United Kingdom scroll up from the top of the list to the bottom by pressing and releasing the **Menu Up** button. Press and release the **Select** button to choose the desired country.
7. You will typically find that you then have the option to select either 'All Stations' or one of a number of categories. The lists are always sorted alphabetically, and long lists will wrap around from top to bottom or bottom to top.

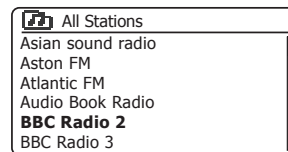
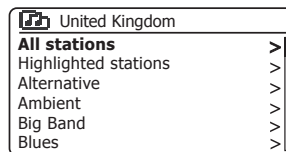
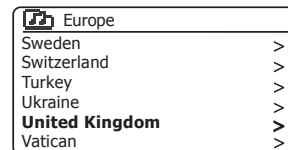
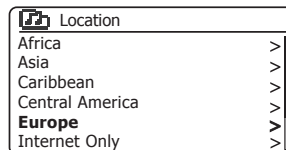
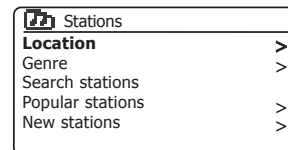
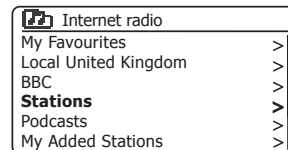
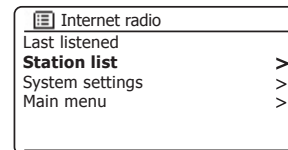
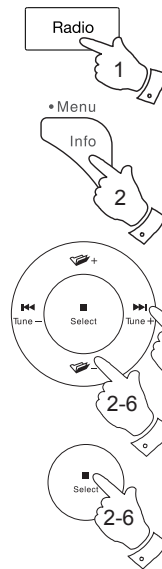

Selecting a radio station by location - cont.

- Press and release the **Menu Up** or **Down** buttons to highlight your chosen radio station and then press and release the **Select** button to enter your selection. The display will show 'Connecting...' while the sound system connects to the new station. The station should then start playing. Adjust the volume as needed.
- If the station has on-demand content, that is, it gives the option of listening to programmes which have already been broadcast or to Podcasts, there will be an additional screen showing the radio station name as well as a 'Podcasts' option.
 

These are selected using additional menus, determined by the radio station and the content. There may simply be a list of programmes, or there may also be options to chose from broadcasts on particular dates or days of the week. The examples shown here are typical.

Podcasts can also be accessed separately from the main Internet Radio menu, see page 28.

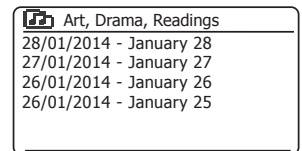
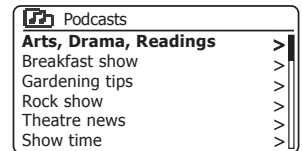
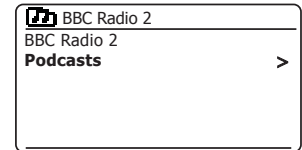
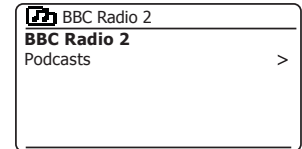
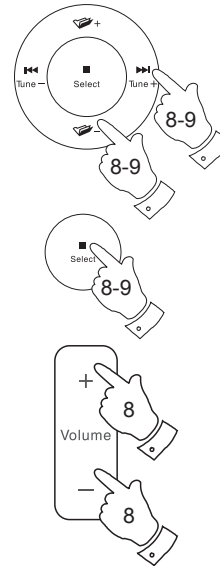

If your radio cannot connect to a radio station

Note: If your sound system is unable to connect to an Internet radio station it will generally either display 'Network Error' or 'Stopped'. This can be for many reasons, but typically will be due to one of the following:

- The radio station may not be broadcasting at the present time.
- The radio station may not be able to accommodate any more connections from internet listeners.
- The broadcaster may limit listening to specific countries or regions
- There may be network congestion (either locally or at a distance) which is affecting the reliability of the connection.

If your sound system can connect, but the audio is not continuous and the radio keeps having to reconnect, this may be due to the radio station only having limited connection capacity.

Please also refer to the 'Troubleshooting' section on page 123.

## Selecting a radio station by genre

1. **Press and hold** the **Menu** button to enter the main Internet Radio menu. Press the **Menu Up** or **Down** buttons until '*Station list*' is highlighted on the display and then press and release the **Select** button.
2. Press the **Menu Up** or **Down** buttons until '*Stations*' is highlighted on the display and then press and release the **Select** button.
3. Press the **Menu Up** or **Down** buttons until '*Genre*' is highlighted on the display and then press and release the **Select** button.
4. Press the **Menu Up** or **Down** buttons to scroll through the list of content types. This menu is normally cyclic - you can scroll the list continually in either direction. When the chosen genre is highlighted, press and release the **Select** button.
5. You then have the choice of '*All Stations*' of the chosen genre, or a list of countries. Note if a country is not shown then the station may still appear in the 'All Stations' list. Press the **Menu Up** or **Down** buttons and press and release the **Select** button to choose as needed.
6. A list of radio stations is then shown. Press the **Menu Up** or **Down** buttons until the desired station name is highlighted on the display.
7. Press and release the **Select** button to select the station. The display will show '*Connecting...*' while it finds the new station. If the radio is unable to connect this may be for one of the reasons explained on page 24.
8. Adjust the **Volume** as needed to set the listening level.

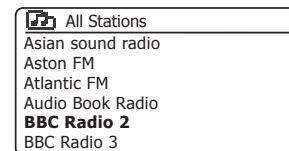
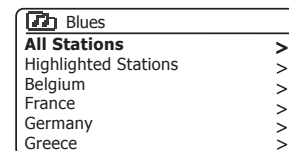
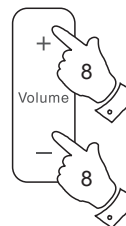
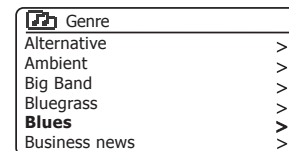
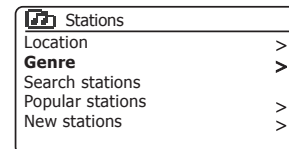
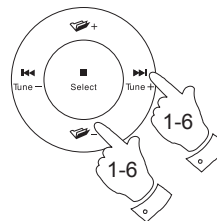
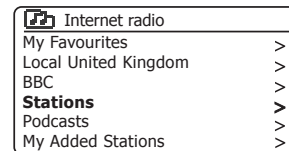
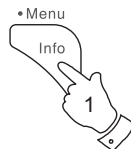

## Searching for a radio station by name

There may be occasions when you know the name of a radio station but you do not know the location or genre. This facility allows you to search for the station using a part (or parts) of the radio station name.

1. **Press and hold the *Menu* button** to enter the main Internet Radio menu. Press the ***Menu Up*** or ***Menu Down*** buttons until '*Station list*' is highlighted on the display and then press and release the ***Select*** button.
2. Press the ***Menu Up*** or ***Menu Down*** buttons until '*Stations*' is highlighted on the display and then press and release the ***Select*** button.
3. Press the ***Menu Up*** or ***Menu Down*** buttons until '*Search stations*' is highlighted on the display and then press and release the ***Select*** button.
4. To enter the search word(s) press the ***Menu Up*** or ***Menu Down***, ***Left*** and ***Right*** buttons to highlight each character for the search in turn, and press and release the ***Select*** button to enter. If you make an error press and release the ***Menu Up*** or ***Menu Down*** buttons or use the ***Info*** button to access the delete character '**[BKSP]**' on the screen and then press and release the ***Select*** button. Press and release the ***Menu Up*** or ***Menu Down*** buttons or press ***Info*** again to go back to the character selection. After the final character of the search has been entered, use the ***Info*** button and then the ***Menu Up*** or ***Menu Down*** buttons to highlight the '**[OK]**' symbol on the screen and then press and release the ***Select*** button to finish.
5. The sound system will search for radio stations that match your search data. If you include a space between two search items the sound system will look for station names which include both items. Thus a search for 'ROCK 100' could find a station called '100 Classic Rock Hits' as well as a station called '100.FM Rocks'
6. Press the ***Menu Up*** or ***Menu Down*** buttons to highlight the station that you wish to listen to and press and release the ***Select*** button to confirm your choice. The display will show '*Connecting...*' while it finds a new station.

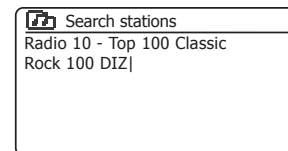
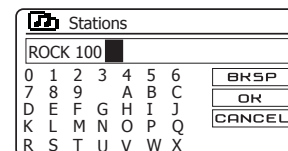
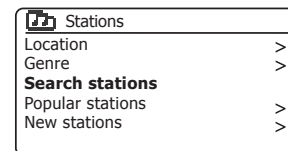
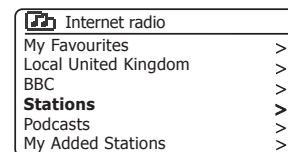
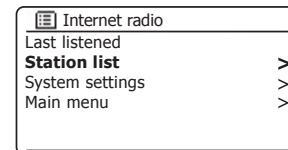
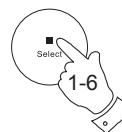
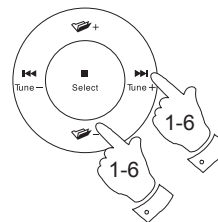
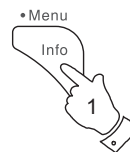

## Selecting a new or popular station

As described in the section 'Internet Radio - the basics' on page 22, your sound system connects via the Internet to a database of radio stations. This option is provided to highlight stations which are newly added to the list of those available, or stations which are particularly popular with listeners around the world. Your sound system allows you to easily choose stations from these two categories, using menus very similar to those used when finding stations by location and genre.

1. **Press and hold** the **Menu** button to enter the main Internet Radio menu. Press the **Menu Up** or **Down** buttons until '**Station list**' is highlighted on the display and then press and release the **Select** button.
2. Press the **Menu Up** or **Down** buttons until '**Stations**' is highlighted on the display and then press and release the **Select** button.
3. Press the **Menu Up** or **Down** buttons until '**Popular stations**' or '**New stations**' is highlighted on the display. Press and release the **Select** button to enter your choice.
4. Press the **Menu Up** or **Down** buttons to highlight the station that you wish to listen to and then press and release the **Select** button to enter your choice. The display will show '**Connecting...**' while the new station is found.

If the sound system is unable to connect to a particular radio station this may be for one of the reasons explained on page 24.

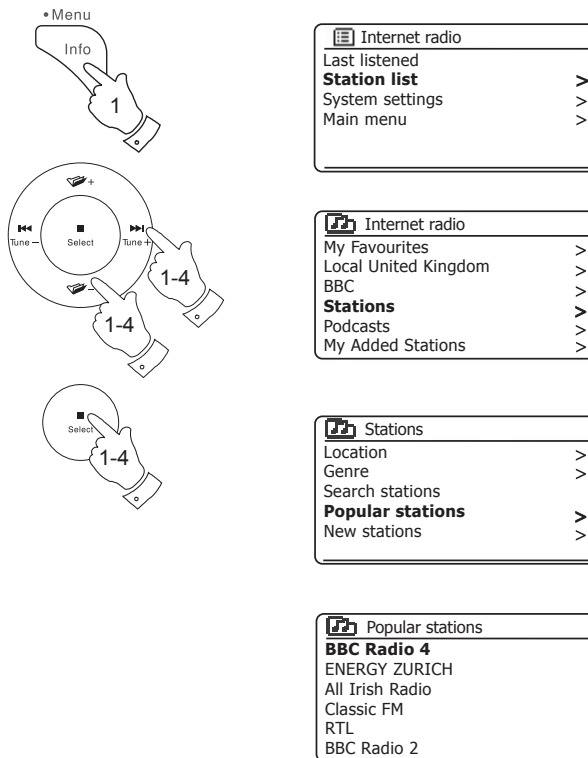

## Selecting a podcast

Radio broadcasters and individuals may make programmes which are intended normally to be downloaded into a computer or copied onto a portable media player. These are commonly known as Podcasts.

Podcasts are also accessible using the Podcasts option on the *Stations* menu (see page 23-24).

1. **Press and hold** the **Menu** button to enter the main Internet Radio menu. Press the **Menu Up** or **Down** buttons until '*Station list*' is highlighted on the display and then press and release the **Select** button.
2. Press the **Menu Up** or **Down** buttons until '*Podcasts*' is highlighted on the display and then press and release the **Select** button.
3. You may then search by location, genre, or using part of the name of the podcast. The searches operate in exactly the same way as when searching for a conventional radio station.

Searching by location is done first by continent, then by country. You may then list '*All shows*' or search within a country by genre.

Searching by genre is more direct, since once the genre is chosen the next menu display shows a list of available podcasts.

Searching by name operates in the same way as when searching for a named radio station, selecting the 'OK' symbol when you have entered the text. You may enter one or more pieces of text which will be used for the search.

4. Press the **Menu Up** or **Down** buttons and then press and release the **Select** button to confirm your chosen podcast. The display will show '*Connecting...*' while it finds the new programme.

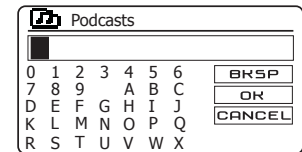
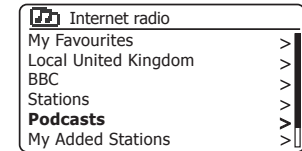
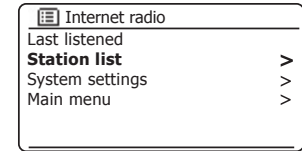
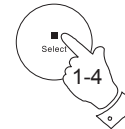
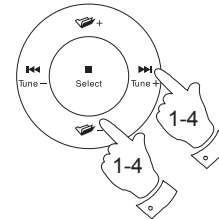
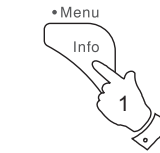

## Presetting stations

With so many Internet radio stations available, it is desirable to have a means of rapidly selecting the stations that you listen to most frequently. Your sound system has ten memory presets for Internet radio which can easily be set to store the details of any Internet radio station or podcast. The radio station presets are retained even when the sound system is switched off.

Please see also the sections 'Last Listened' on page 34 and 'Configuring My Favourite Stations' on page 33.

### Storing a preset 1-10 using remote control

1. Press the **On/Standby** button to switch on your sound system. Tune to the required station using one of the methods described on the preceding pages.
2. To store the currently playing radio station as a preset, **press and hold** the required **Preset** button (1 - 10) on the remote control until the display shows 'Preset stored'.
3. Stations that are already stored in the presets may be over-written by following the procedure described above.

### Recalling a preset 1-10 using remote control

1. Press the **On/Standby** button to switch on your sound system. Select the Internet Radio mode using the **Radio** button.
2. Momentarily press and release the required **Preset** button on the remote control. Your sound system will then connect to the station stored in the preset memory. The preset used will be shown at the bottom of the display screen.

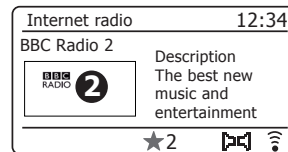
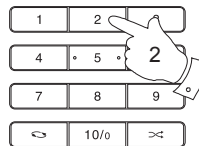
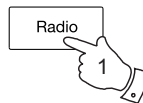
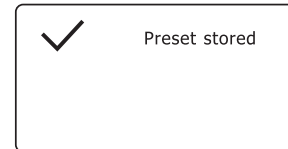
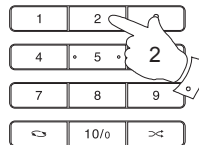



## Storing a preset using the menu

1. Press the **On/Standby** button to switch on your sound system. Tune to the required station using one of the methods described on the preceding pages.
2. **Press and hold** the **Select** button. The display will show a 'Save to Preset' menu.
3. Press the **Menu Up** or **Down** buttons to scroll through the preset list until you reach an unused preset or a preset that you wish to change. Press and release the **Select** button to store the preset. 'Preset stored' will be shown on the display. Repeat this procedure as needed for the remaining presets.
4. Stations which are already stored in the presets may be over-written by following the procedure above.

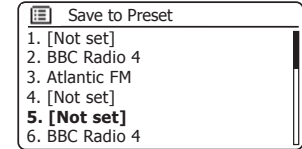
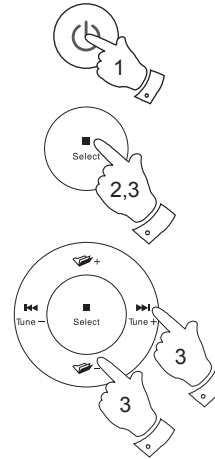

## Recalling a preset using the menu

1. Select the **Internet radio** mode using the **Radio** button.
2. Press and release the **Select** button to display the 'Recall from Preset' menu.
3. Press the **Menu Up** or **Down** buttons to select the desired preset station. Press and release the **Select** button.

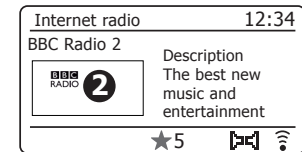
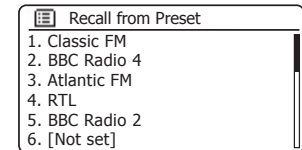
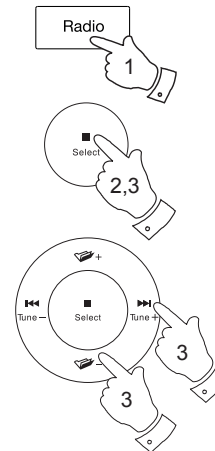

Your sound system will then connect to the station stored in the preset memory. The preset used will be shown at the bottom of the display screen.

## Display modes

Your sound system has a range of display options when in Internet Radio mode. Note that not all information may be available for all Internet radio stations.

1. Press and release the **Info** button to cycle through the different options.

Description	Displays information about the radio station or scrolling text messages such as artist/track name, phone number etc.
Genre	Displays programme type information e.g. Pop, Classic, News, etc. and the location of the current radio station.
Reliability	Displays the reliability of the data stream from the station currently being received.
Format	Displays the bit rate and format of the station being received.
Playback buffer	Displays status when connecting to and playing a radio station. This indicates the reliability of the data stream to your radio. If there are no bars shown to the right of the dividing line then the data stream reliability may be poor and you may find that there are many breaks in the audio.
Date	Displays the current date.

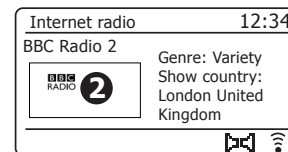
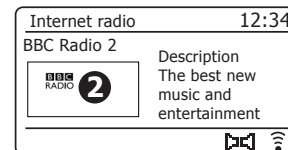
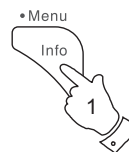

Additional or alternative information may be displayed when listening to Podcasts. Categories displayable can include...

Episode name	Show description
Show genre	Show language
Episode URL	Bit rate
Codec	Sampling rate

Whenever the sound system is displaying an information screen (as opposed to a menu screen), the time is displayed in the top-right corner of the display, and a WiFi strength or Ethernet connection indicator is shown in the bottom-right corner.

## Customising your stations list

In addition to storing your favourite radio stations in the radio presets, your sound system allows you to create customised lists of stations which can appear in two special menus on the radio called *'My Favourites'* and *'My Added Stations'*.

Your sound system uses a database which is accessed via the Internet in order to find out which radio stations are available and how it should connect to them. You are able to add your personal selections to this database. These will only be accessible by you using your PC or your sound system. You can choose the stations which will appear in the *'My Favourites'* menu from the large selection already listed. Additionally, if you find a radio station that is not listed then you may also add the Internet address (URL) of the station's audio stream to your selection. It will then appear on your sound system via the *'My Added Stations'* menu item.

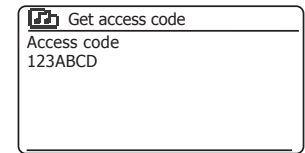
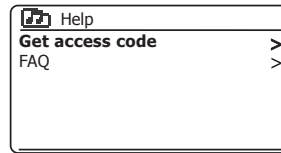
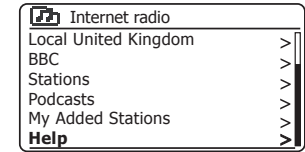
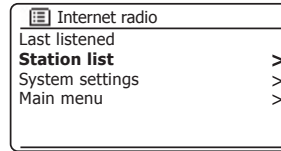

## Registering an account

1. Open the web site <http://www.wifiradio-frontier.com> using the Internet browser on your computer. Click on the *'Register here'* link and follow the on-screen instructions to register an account. During the registration process the web site asks for an access code. This allows it to uniquely identify your Internet radio from the many others that it also provides data for. To obtain the access code, please follow these steps.
2. With your sound system switched on and in Internet Radio mode, **press and hold** the **Menu** button, then select *'Station list'* using the **Menu Up** or **Down** and the **Select** buttons.
3. Scroll down the Station List menu to the item called *'Help'*. Press and release the **Select** button to enter the Help menu.
4. In the Help menu, select the menu item *'Get access code'*. Provided that the sound system is connected to the Internet, a code will be displayed of typically seven characters (upper case letters and numbers). Make a note of this code for the next step. If you need to re-register later you must repeat this process to get a fresh access code.
5. You should then use the code displayed by the sound system to fill in the Access Code field on the web page when you set up your account.

Once you have your account set up, if you have other radios which use the same database, you may also add them to your account. You will need to get an access code from each radio in order to add it to the account. They may then share your favourite and added radio station details.

## Customising your stations list - cont.

### Configuring My Favourite Stations

1. Using the web site at <http://www.wifiradio-frontier.com> it is possible to search among the many radio stations that are available by location, genre, or language. You may also choose from new or popular stations.
2. When the radio stations that you have found are shown on your computer screen, they are shown with a 'Play' icon and an 'Add to favourites' icon (the plus symbol and heart). Clicking on the 'Play' icon will allow you to hear the radio station via your computer. Clicking on the 'Add to favourites' icon will cause the radio station to be added to the list accessible via your sound system.
3. To help you organise your favourites, and since you may have a great many after a while, the web site will allow you to specify the name for a category or group under which the radio station will be listed on your sound system. Suitable names might be 'Rock', 'Smooth', 'Mum's stations', and so on. When ever you add another radio station to your favourites you can either add it to an existing category or create a new one.
4. Once you have Internet radio stations available in your My Favourite Stations list, you may play these stations from your sound system. These stations will be available on your sound system from the Internet Radio menu item *'My Favourites'*.
5. To look at, modify or delete your favourite stations lists on the web site, use the link *'My favourites'* in the *'My account'* area. To delete a favourite radio station, click on the icon with a heart and minus symbol.

### Configuring My Added Stations

1. If you wish to listen to a radio station which is not currently held in the database at <http://www.wifiradio-frontier.com> it is possible to add the details yourself. You will need to obtain the internet address (URL) for the audio stream for the station that you wish to add. This may be information provided by the radio station itself, via its web site, or perhaps passed to you from another listener.  
**Note:** The URL for the audio stream will generally *not* be the URL for the web page from which you listen to the station on your PC.
2. Use the *'My added stations'* link in the *'My account'* area on the web site. This allows you to add details of new stations or to modify those already added. You can provide a name for the radio station which will be shown on your sound system. You must also provide the web address, location and format details.
3. Once you have Internet radio stations available in your My Added Stations list, you may play these stations from your sound system. These stations will be available on your sound system from the Internet Radio menu item *'My Added Stations'*.
4. It is possible to add the web addresses for audio streams which may not be playable by your sound system. If you attempt to play such a stream, your sound system will normally display an error message of some kind. The Roberts S300 can only play MP3, WMA and AAC Internet radio streams.
5. To look at, modify or delete your added stations list on the web site, use the link *'My added stations'* in the *'My account'* area. To delete an added radio station, click on the icon with a heart and minus symbol.

## Last Listened

It is often helpful to be able to go back to a station that you have recently listened to. Your sound system has a 'Last Listened' feature which provides you with quick access to the ten most recently listened to radio stations or podcasts. As each new radio station is listened to the oldest item is deleted from the list. The Last Listened list is stored when the sound system is disconnected from the mains.

1. With the sound system switched on and in Internet Radio mode, **press and hold** the **Menu** button. The first item on the menu is '*Last listened*'. With this item highlighted press the **Select** button.
2. The display will then show a list of the last ten Internet radio stations or podcasts. Press the **Menu Up** or **Down** buttons to highlight whichever you wish to listen to and then press the **Select** button to cause your sound system to reconnect to that radio station or podcast.

## Storing favourite stations

It is also possible to store your favourite radio stations whilst playing a station on your sound system.

1. Press the **On/Standby** button to switch on your sound system.
2. Tune to the required station using one of the methods described on the preceding pages.
3. Press and hold the **Play/Pause** button. The display will show '*Favourite added*'.
4. These stations will be available on your sound system from the Internet Radio menu item '*My Favourites*', see '*Selecting your favourite stations*' overleaf.

Repeat this procedure as needed to store other favourite stations.

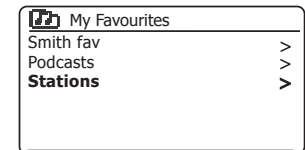
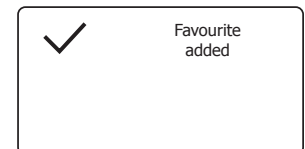
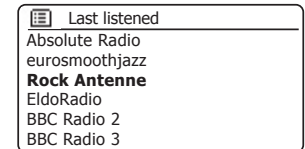
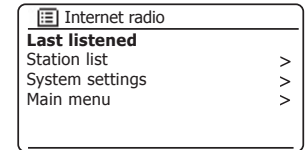
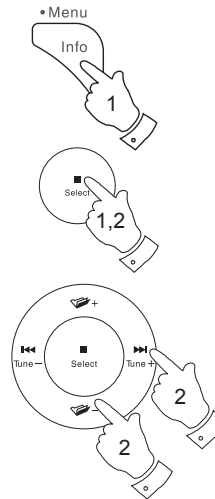

## Selecting your Favourite stations or My Added stations

1. **Press and hold** the **Menu** button to enter the main Internet Radio menu.
2. Press the **Menu Up** or **Down** buttons until '*Station list*' is highlighted on the display. Press and release the **Select** button to enter the menu.
3. Press the **Menu Up** or **Down** buttons until '*My Favourites*' or '*My Added Stations*' is highlighted on the display. Press and release the **Select** button and your favourite stations list or your added stations list will appear on the display (set up as described on page 33).
4. Press the **Menu Up** or **Down** buttons to highlight the required station and then press and release the **Select** button to confirm your selection.  
The display will show '*Connecting...*' while it finds the new station.

If the station has on-demand content such as Podcasts, please see page 28, 'Selecting a Podcast'.

Should you be unable to connect to a particular station, please note that some radio stations do not broadcast 24 hours per day, and some stations are not always on-line.

In addition, as mentioned on page 33, it is possible to specify audio streams for '*My added stations*' which are not compatible with your sound system. In this event the station will not be playable. The Roberts S300 can only play MP3, WMA and AAC internet radio streams.

Note that the audio coding formats listed are generic terms. There are many variations of each format, as well a variety of streaming protocols in use by different radio broadcasters. Your sound system has been designed to play the vast majority of coding and streaming formats in current use by broadcasters.

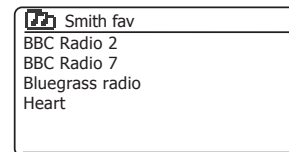
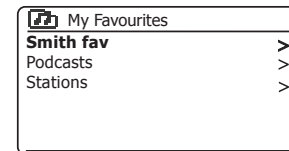
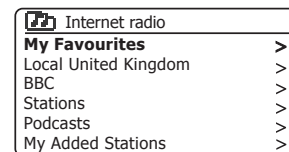
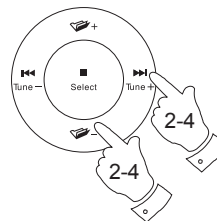
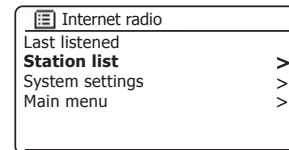
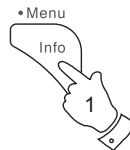

# DAB Radio

### Using DAB mode for the first time

1. Carefully extend the telescopic aerial.
2. Press the **On/Standby** button to switch on the sound system. If the sound system has been used before the last used mode will be selected.
3. Press the **Radio** button as needed so that DAB Radio mode is selected on the display.
4. If this is the first time that DAB mode is used a scan of the Band III DAB channels will be carried out. The display will show 'Scanning'. (If the sound system has been used before the last used station will be selected instead.)

During the scanning process, as new stations are detected the station counter will increase and the stations will be added to the list which is stored in the sound system. The bar graph indicates the progress of the scan.

5. When scanning is completed the radio will list the stations found (in numeric-alpha order 0....9...A...Z), unless it has previously been tuned to a DAB station.

Press the **Menu Left** or **Right** buttons to scroll through the list of available DAB radio stations.

Press and release the **Select** button to select the highlighted station. The display may show 'Connecting...' while the radio re-tunes.

Use the **Volume** buttons to set the sound level as needed.

6. If the station list is still empty after the scan the display will show 'Service not available'. If no stations are found it may be necessary to relocate your sound system to a position giving better reception.

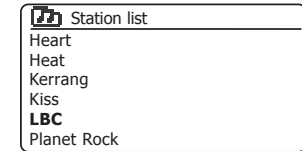
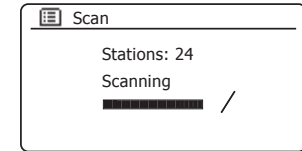
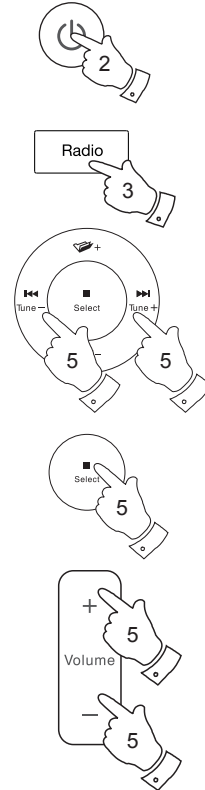

## Selecting a DAB radio station

1. When playing a DAB radio station, the display normally shows the name of the current station with other related information.
2. Press the **Menu Left** or **Right** buttons to access the radio station list and to scroll through the available stations.
3. Press and release the **Select** button to select the highlighted station. The display may show 'Connecting...' while the radio re-tunes.
4. Use the **Volume** buttons to set the sound level as needed.

**Note:** If the display shows 'Station Not Available' it may be necessary to relocate your sound system to a position giving better reception.

A question-mark in front of the station name merely indicates that the station has not recently been detected by the sound system. It may still be available.

The use of the radio station presets is described on page 49.

## Secondary services

Some DAB radio stations can have one or more secondary stations associated with them. Typically these are not broadcast continually. If a station has a secondary station available then the secondary will appear in the list of station names beneath the main (or primary) station. Examples are the programmes 'Daily Service' and 'Parliament' on BBC Radio 4.

1. To listen to a secondary service, use the **Menu Left** or **Right** buttons to scroll to the chosen station, and press and release the **Select** button to tune to the station.

If the secondary service is not available (off-air) then the primary service will be selected.

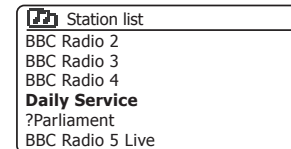
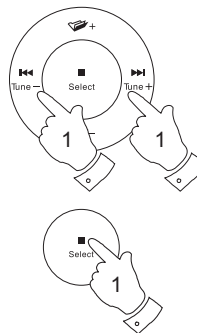
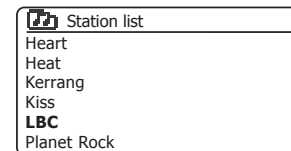
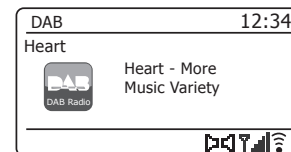
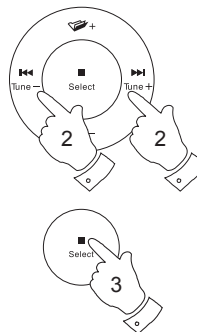



## Display modes

Your sound system has a range of display options when in DAB mode:-

1. Press and release the **Info** button to cycle through the different options.

Text	Displays text messages such as the artist or track name, phone in number, traffic alerts, etc.
Program Type	Displays the type of station being listened to such as Pop, Classic, News etc.
Multiplex / Frequency	Displays the name of the DAB multiplex to which the current station belongs as well as its broadcast frequency.
Signal error / strength	Displays the signal error and strength for the station being listened to. A lower error number indicates a better quality of radio signal. The signal strength graph can be used when positioning the radio or its antenna. For good reception the graph should occupy three or more blocks.
Bit rate and audio type	Displays the digital bit rate and audio coding information for the station being listened to.
Date	Displays the current date.
DL Plus text	Some stations may provide other programme related information for the display in addition to the regular text. If none is available, a message "[No DL+]" is displayed.
Slideshow	If a DAB broadcast provides a slideshow image, this may be viewed full-screen by pressing and holding the back button.

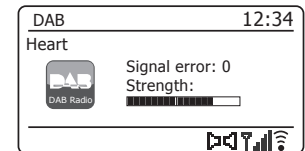
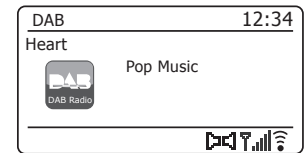
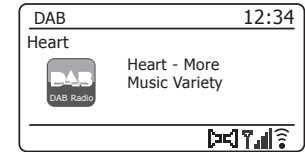
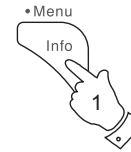

A signal strength indicator is always shown in the lower area of the display on the right hand side. If the broadcast being received is in stereo, then the stereo speaker symbol will be shown.

If the currently tuned station has been stored as a preset, then the preset number will also be shown (see page 49).

## Finding new DAB radio stations

Should you wish to use your sound system for DAB reception in a new location, or if no stations were detected during the initial scan, you can follow this procedure to allow your sound system to find out which DAB radio stations are available.

1. Ensure that the telescopic antenna is extended, and then press the **Radio** button as needed to select DAB Radio mode.
2. Once in DAB mode **press and hold** the **Menu** button.
3. Press the **Menu Up** or **Down** buttons until 'Scan' is highlighted on the display.
4. Press and release the **Select** button to initiate the scan. The display will show 'Scanning' and your radio will perform a scan of the Band III DAB frequencies. As new stations are found the station counter will increase and stations will be added to the list. The bar graph indicates the progress of the scan.
5. Alternatively, press the **Auto Tune** button on the remote control to initiate a scan of the DAB Band III frequencies.  
The Auto Tune button may not operate in all display modes. In this case use the menu option above.

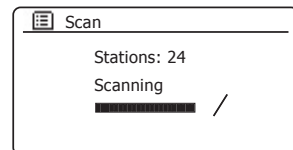
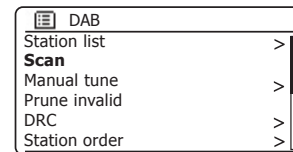
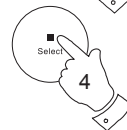
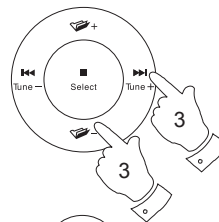
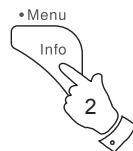
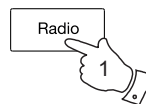

## Manual Tuning

Manual tuning allows you to tune directly to the various Band III DAB channels (5A to 13F).

1. When in DAB mode **press and hold** the **Menu** button so that the display shows the DAB menu.
2. Press the **Menu Up** or **Down** buttons until '**Manual tune**' is highlighted.
3. Press and release the **Select** button to enter manual tune mode.
4. Press the **Menu Up** or **Down** buttons to choose the required DAB channel.
5. Press and release the **Select** button to cause the radio to tune to the chosen channel.

When the radio has tuned, the display shows the channel number and frequency, and the name of the DAB multiplex found (if any).

A bar graph shows the signal strength and is useful if you need to reposition the sound system or its aerial. The minimum signal marker 'I' which separates the left and right parts of the signal graph shows the minimum signal level required for satisfactory reception.

Any new radio stations found on the tuned DAB multiplex will be added to the list stored in the sound system.

6. Press the **Back** button to choose a different frequency.
7. Press the **Back** button a second time to access the main DAB menu then select '**Station list**' to return to normal tuning.

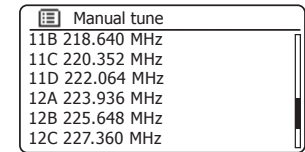
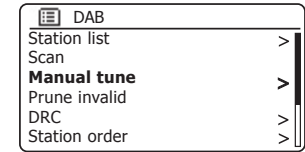
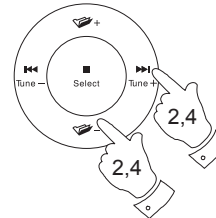
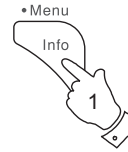

## Dynamic Range Control settings

Dynamic Range Control (also known as DRC) can make quieter sounds easier to hear when your sound system is used in a noisy environment by reducing the dynamic range of the audio signal.

1. Press the **On/Standby** button to switch on your sound system.
2. Press the **Radio** button as needed to select DAB Radio mode.
3. **Press and hold** the **Menu** button to enter the DAB menu.
4. Press the **Menu Up** or **Down** buttons until '**DRC**' is highlighted on the display.
5. Press and release the **Select** button to enter the DRC adjustment mode. The current DRC setting will be indicated with an asterisk.
6. Press the **Menu Up** or **Down** buttons to highlight the required DRC setting (the default is Off).  
'**DRC Off**' - DRC is switched off, Broadcast DRC will be ignored.  
'**DRC high**' - DRC is set as sent by broadcaster.  
'**DRC low**' - DRC level is set to 1/2 that sent by broadcaster.
7. Press and release the **Select** button to confirm the setting.

Note: Not all DAB broadcasts use the DRC function. If the broadcast does not provide DRC information, then the DRC setting in the sound system will have no effect.

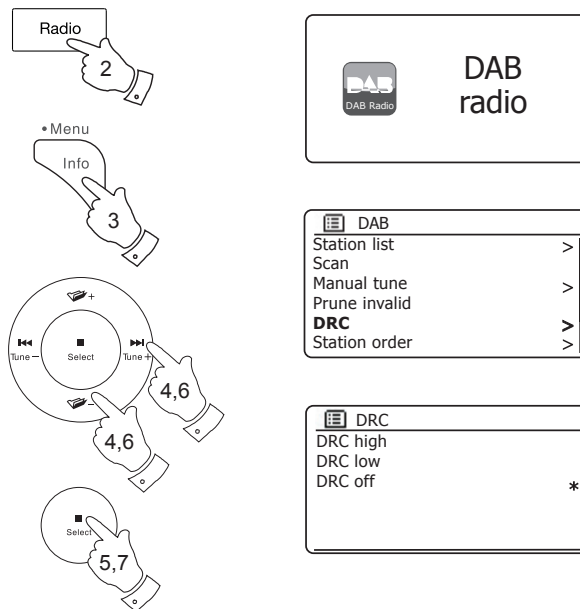

## Station order setup

Your sound system has 3 station order settings from which you can choose. The station order settings are, alphanumeric, ensemble and valid.

Note: The default station order on your radio is alphanumeric.

1. Press the **On/Standby** button to switch on your sound system.
2. Press the **Radio** button as needed to select DAB Radio mode.
3. **Press and hold** the **Menu** button to enter the DAB menu list.
4. Press the **Menu Up** or **Down** buttons until 'Station order' is highlighted. Press the **Select** button to enter the station order adjustment mode.
5. Press the **Menu Up** or **Down** buttons to choose between 'Alphanumeric', 'Ensemble' and 'Valid'.  
 'Alphanumeric' - sorts the station list alpha-numerically 0...9 A...Z.  
 'Ensemble' - organises the station list by DAB multiplex.  
 'Valid' - shows only those stations for which a signal can be found.  
 The current setting is indicated by an asterisk.
6. Press and release the **Select** button to select the required station order.
7. Press the **Back** button as needed to return to the DAB menu or to the stations list.

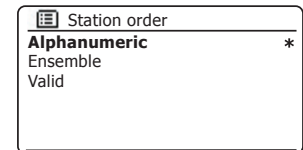
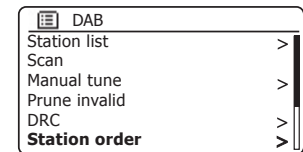
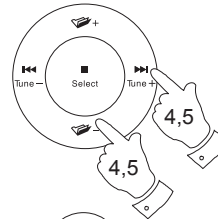
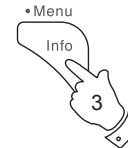
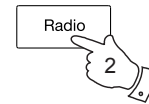

## Prune stations

If you move to a different part of the country, some of the stations which were listed may no longer be available. Also, from time to time, some DAB services may stop broadcasting, or may change location or frequency. Stations which cannot be found, or which have not been received for a very long time are shown in the station list with a question mark.

The Prune stations function will delete the marked DAB stations from your station list.

1. Press the **On/Standby** button to switch on your sound system.
2. Press the **Radio** button as needed to select DAB Radio mode.
3. **Press and hold** the **Menu** button to enter the DAB menu.
4. Press the **Menu Up** or **Down** buttons until '**Prune invalid**' is highlighted. Press and release the **Select** button.
5. To cause the stations list to be pruned, eliminating unavailable stations press the **Menu Up** or **Down** buttons until '**YES**' is highlighted on the display.
6. Press and release the **Select** button to cause the invalid station names to be removed from the station list.

If you do not wish to prune stations, highlight '**NO**' and then press and release the **Select** button. The display will revert to the previous menu.

**Note:** If you have moved your sound system to a different part of the country you should also carry out a search for new stations (please see the section 'Finding new stations' on page 39).

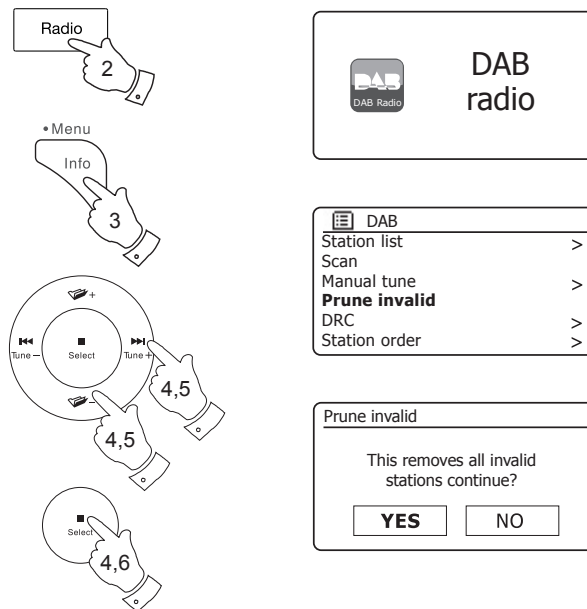

# FM Radio

## Operating your radio in FM mode

1. Carefully extend the telescopic aerial and press the **On/Standby** button to switch on your sound system.
2. Press the **Radio** button as needed to select *FM radio* mode.
3. **Press and hold** the **Menu Left** or **Menu Right** button on your sound system to scan the FM band.
4. The display will show the frequency of the signal which has been found. If RDS information is available, after a few seconds the display will show the radio station name.
5. To find more FM stations repeat the scan operation. Your sound system will scan the FM band from the currently displayed frequency and will stop scanning when it finds a signal of sufficient strength.
6. Alternatively the **Auto Tune** button (on the remote control) can also be used.  
If you only hear hiss or interference, simply press the **Auto Tune** button to scan further. Your radio may have found a spurious interference signal.
7. When the end of the waveband is reached your radio will recommence tuning from the opposite end of the waveband. Use the **Volume** buttons to adjust the sound level as needed.

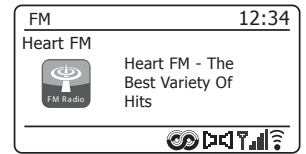
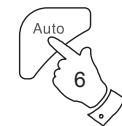
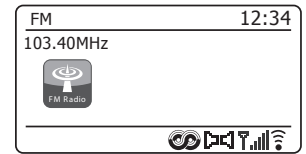
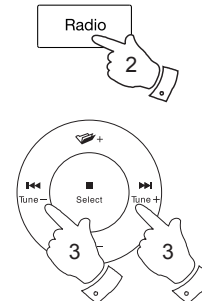

## Manual tuning

1. Carefully extend the telescopic aerial and press the **On/Standby** button to switch on your sound system.
2. Press the **Radio** button as needed to select FM Radio mode.
3. Press and release the **Menu Left** or **Right** to control the frequency that the radio will tune to. The frequency will change in steps of 50kHz.

When the end of the waveband is reached the radio will recommence tuning from the opposite end of the waveband.

4. Use the **Volume** buttons to adjust the sound level as needed.

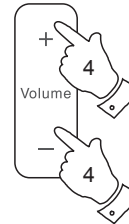
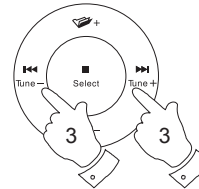
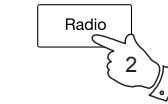



## Display modes

Your sound system has a range of display options when in FM mode:-

1. Press and release the **Info** button to cycle through the different options.

- a. Text Displays text messages such as the artist or track name, phone in number, traffic alerts, etc.
  
- b. Program Type Displays the type of station being listened to such as Pop, Classic, News etc.
  
- c. Frequency Displays the frequency of the FM signal.
  
- d. Date Displays the current date.

Note: If no RDS information is available, then the sound system will only be able to display the frequency. There will be no text or programme type information available under these conditions.

The sound system only provides displays when there is information available. So if there is no text, for example, that display is not available.

The RDS indicator at the bottom of the display shows that there is some RDS data present in the broadcast being received.

The stereo speaker display shows that the sound system is receiving a stereo broadcast (please see also 'Stereo/Mono switching' on page 48).

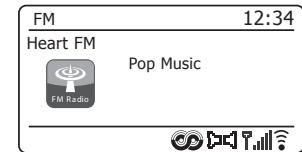
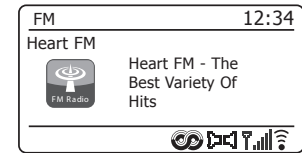
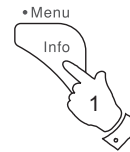

## Scan setting

When using the FM mode your sound system can be set to either scan local stations or to scan all stations including distant radio stations.

1. Press the **Radio** button as needed to select FM Radio mode.
2. **Press and hold** the **Menu** button to enter the FM menu.
3. Press the **Menu Up** or **Down** buttons until '*Scan setting*' is highlighted and then press and release the **Select** button to enter the scan adjustment mode.  
The current scan setting is indicated with an asterisk.
4. To set your radio so that only the stations with the strongest signals are found during scanning press the **Menu Up** or **Down** buttons until '*YES*' is highlighted. Press and release the **Select** button to confirm the setting. (Normally this will restrict scanning to local transmissions.)

Alternatively, to set your radio so that all available stations are found during scanning (local and distant transmissions) press the **Menu Up** or **Down** buttons until '*NO*' is highlighted. Press and release the **Select** button to confirm the setting.

5. Press the **Back** button to return to the normal FM mode display.

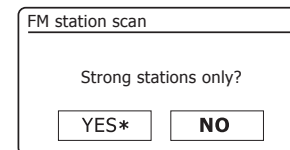
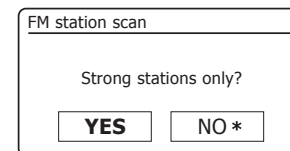
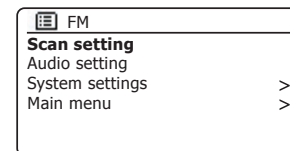
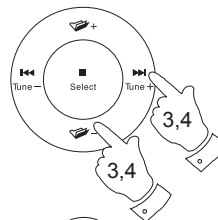
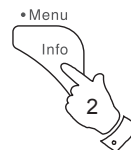
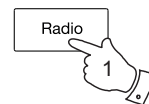

## Stereo / Mono switching

If the FM radio station being listened to has a weak signal, some hiss may be audible. It is possible to reduce this hiss by forcing the sound system to play the station in mono rather than stereo.

1. Press the **Radio** button as needed to select the FM Radio mode display and tune to the required FM station as previously described.
2. **Press and hold** the **Menu** button to enter the FM menu.
3. Press the **Menu Up** or **Down** buttons until 'Audio setting' is highlighted on the display. Press and release the **Select** button to enter the audio setting mode.  
The current setting is indicated with an asterisk.
4. To switch to mono in order to reduce the hiss from a weak FM signal press the **Menu Up** or **Down** buttons until 'YES' is highlighted. Press and release the **Select** button to confirm the setting.

Alternatively, to return to the normal automatic 'stereo or mono' mode press the **Menu Up** or **Down** buttons until 'NO' is highlighted. Press and release the **Select** button to confirm the setting.

5. Press the **Back** button to return to the normal FM mode display.

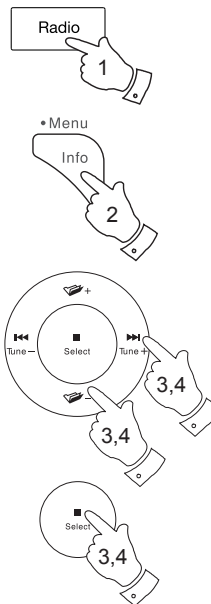

## FM Radio

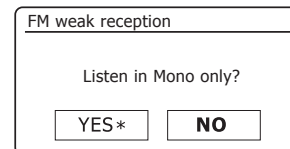
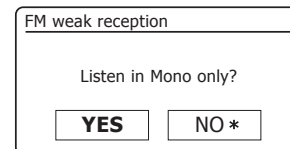
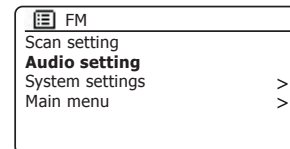

## Presetting stations

Your sound system has ten memory presets each for DAB and FM radio. They are used in the same way for each operating mode.

The radio station presets are retained even when the sound system is switched off.

### Storing a preset 1-10 using remote control

1. Press the **On/Standby** button to switch on your sound system.
2. Tune to the required station using one of the methods described on the preceding pages.
3. To store the currently playing radio station as a preset, **press and hold** the required **Preset** button (1 - 10) on the remote control until the display shows **'Preset stored'**. The station will be stored using the chosen preset button. Repeat this procedure as needed for the remaining presets.
4. Stations that are already stored in the presets may be over-written by following the procedure described above.

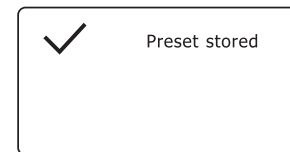
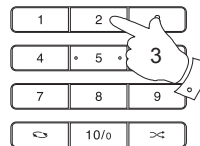

### Recalling a preset 1-10 using remote control

1. Press the **On/Standby** button to switch on your sound system. Select the DAB or FM Radio mode using the **Radio** button.
2. Momentarily press the required **Preset** button on the remote control. Your sound system will then connect to the station stored in the preset memory. The preset used will be shown at the bottom of the display screen.

**Note:** You may select a stored preset by pressing the **Menu Up** or **Down** buttons. The preset indicator will show on the bottom of the display screen.

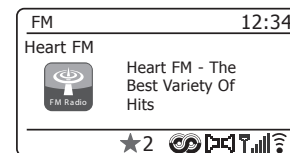
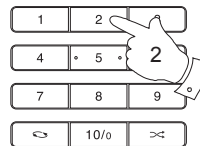
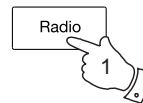

## Storing a preset using the menu

1. Press the **On/Standby** button to switch on your sound system. Tune to the required station using one of the methods described on the preceding pages.
2. **Press and hold** the **Select** button. The display will show a 'Save to Preset' menu.
3. Press the **Menu Up** or **Down** buttons to scroll through the preset list until you reach an unused preset or a preset that you wish to change. Press and release the **Select** button to store the preset. 'Preset stored' will be shown on the display. Repeat this procedure as needed for the remaining presets.
4. Stations which are already stored in the presets may be over-written by following the procedure above.

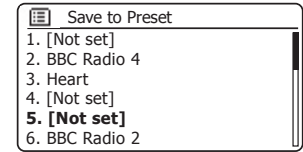
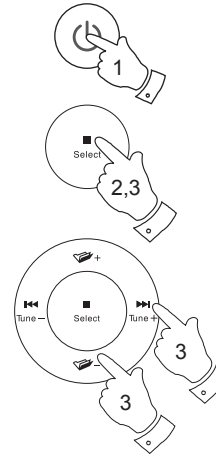

## Recalling a preset using the menu

1. Select the **DAB** or **FM** radio mode using the **Radio** button.
2. Press and release the **Select** button to display the 'Recall from Preset' menu.
3. Press the **Menu Up** or **Down** buttons to select the desired preset station. Press and release the **Select** button.

Your radio will then connect to the station stored in the preset memory. The preset used will be shown at the bottom of the display screen.

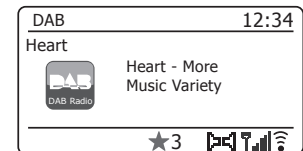
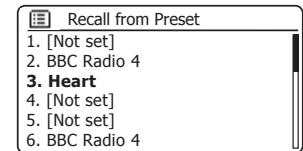
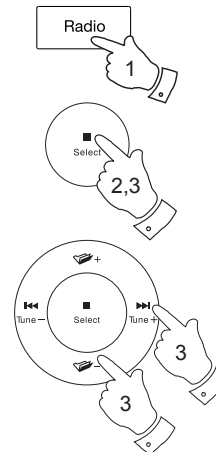

# Music Player

## Use with Windows, Apple Mac, Linux

The Music Player allows you to play audio files which are stored on another device connected to your network.

Networked devices that could hold audio files can include computers, smart phones, tablets, Network Attached Storage (NAS) units, and network routers which have UPnP / DLNA file sharing capability. In order to play files from a device on your network, your sound system must connect to a file server program on that device which uses the Universal Plug and Play (UPnP) protocol (often known as DLNA).

If the device is a computer or tablet using Windows, then it probably already has a UPnP server program available in the form of Windows Media Player (WMP). This allows you to share your files to devices on your network, and you may then select files by Album, Artist, and so on using your sound system's controls. WMP can serve MP3, WMA, AAC and WAV files to your sound system (and FLAC files from Windows 10).

If you are an Apple MacOS, Linux, iOS or Android user, or if you have your audio files stored in other formats, such as ALAC, there are many other UPnP server programs available. Note that Apple computers do not support UPnP streaming natively and third party software is required for this task. If you wish to use a DLNA server built into your NAS or network router, you should consult your manufacturer's documentation on how this should be configured.

The Music Player on the sound system can play audio files in MP3, WMA, AAC, ALAC, FLAC and WAV formats. WMA Lossless files can also be played when using Windows Media Player as the UPnP server. Note that the playback of files encoded using WMA Voice, WMA 10 Professional, and of files which have DRM protection is not supported by the sound system.



Please note that when using a UPnP/ DLNA server, the search and selection criteria that are available to the user are determined by the server software, and not by the device playing the content. Typical searches include Artist, Album and Genre. Many server applications also allow you to access your files according to the folders within which they are stored as well as other criteria. Windows Media Player is less flexible than some other UPnP servers in this regard, but is generally easier to set up.

Many UPnP server applications are also capable of sharing pictures and video files to other network connected devices. If this is the case (as it is with Windows Media Player) you may see the option of choosing between 'Music', 'Video' and 'Pictures' on the Music Player's menu. Clearly you should only select the 'Music' option. Content offered via the alternative options will not be playable on your sound system.

Some third party server applications allow customisation of the search criteria and indexing methods. This can be useful if you have a very large collection of stored music files.

It is not possible in this book to describe server applications for all available environments, and neither is it practical to describe how to get the best out of each. Windows Media Player is used as an example in this case, although many of the principles are applicable to other servers as well. The access to the media, the choice of media for playing, and the use of the media playback controls from the product or from its controlling app are similar regardless of the UPnP / DLNA server being used.

When using your sound system as part of a group of multi-room products, audio files in ALAC and FLAC formats will only play on the group master (see page 124).

## Accessing your audio files via a UPnP server

If your computer is running Windows 7, 8, or 10, then Windows Media Player includes a UPnP server which will make your files available to your sound system. There are other UPnP server solutions available for non-Windows users and for Windows users who may wish to use an alternative (see the preceding page).

It is beyond the scope of this instruction book to cover all possible options for UPnP. We explain the use of Microsoft's Windows Media Player here since that will be the first choice for the majority of users.

### Set up UPnP access with Windows Media Player

1. At the time of writing, Windows 7, 8, and 10 all use Windows Media Player version 12 (referred to here as WMP 12), and the configuration is similar in each case. WMP 12 can create a library from all the media files available to it on your PC. To add new media files to the library, select *'Library'*, then *'Music'*, then *'All music'* or *'Artist'*, *'Album'* etc. This will show you the current library contents. You may then simply drag and drop files from other locations into the library. Alternatively, with media files or folders on the screen, you may right-click on the file or folder and select *'Include in library'* and then select *'Music'*. In this way you can quickly add additional content to your music library.
2. In WMP 12, click on *'Stream'* (see picture at right) and then select *'Automatically allow devices to play my media'*. Then accept the *'Automatically allow all computer and media devices'* option. There are other options (see overleaf) but this is the simplest if you just wish to quickly enable media streaming to your sound system.
3. Press and release the **On/Standby** button to switch the sound system on. Then press the **Media** button as needed until the *Music Player* mode display is shown. The main *'Music Player'* menu will then be displayed.

### Enabling Media Streaming in Windows Media Player 12

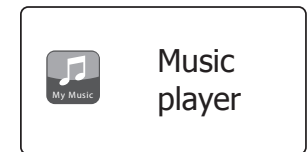
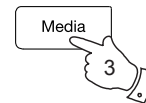
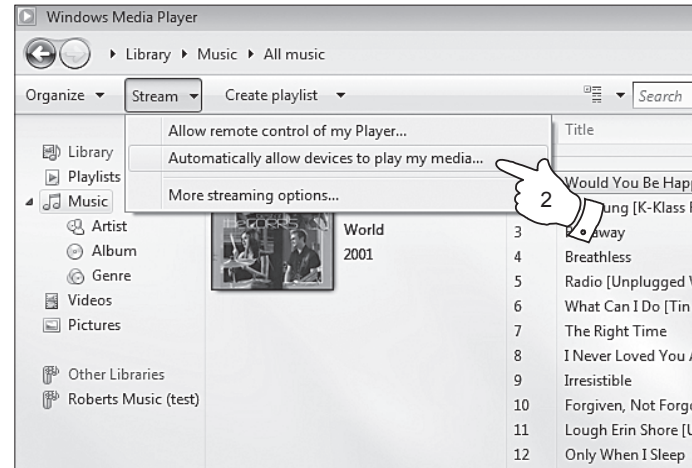

## Set up UPnP access on a Windows PC - cont.

- Press the **Menu Up** or **Down** buttons until '*Shared media*' is highlighted and press the **Select** button to select. The sound system will scan for all available UPnP servers. It may take a few seconds for the sound system to complete its scan. The sound system will display '<Empty>' if no UPnP servers are found.

- After scanning, select your UPnP server using the **Menu Up** or **Down** and **Select** buttons. If you allowed automatic connection previously, your sound system should now connect and you may skip to the next page.

If you did not permit automatic connections, your sound system will then normally display '*Unauthorised*' at this stage.

- Your PC may prompt you that there has been a connection to your UPnP server. Whether prompted or not, in order that the sound system may access the music files, you will need to click the '*Library*' tab in WMP 12 and select the '*Stream...*' item to open the '*Media Streaming*' window. Select '*Automatically allow devices to play my media*' then select '*Automatically allow all computer and media devices*'.

Alternatively select '*More Streaming options*' to enable sharing on a 'per device' basis.

- In the '*More streaming options*' window, the sound system may be listed as a blocked device. Click on the button shown to select '*Allowed*'.

Note: If you are using Microsoft's Windows' firewall software, this should be correctly configured by WMP 12. If you are using third party firewall software you may need to manually configure it to allow your unit and WMP 12 to communicate (see the 'Troubleshooting' section on page 123).

- On the sound system, select the named server again using the **Menu Up** or **Down** and **Select** buttons. If WMP 12 is now able to communicate with your sound system you will be presented with some media selection options on the display.

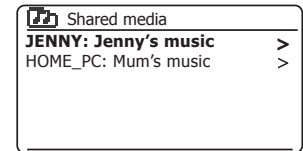
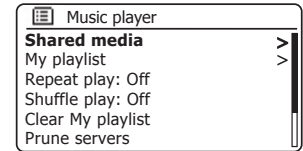
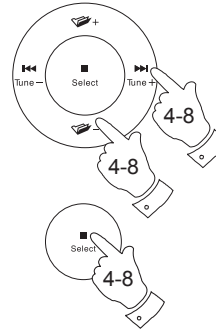

### Allowing a device to connect to Windows Media Player 12

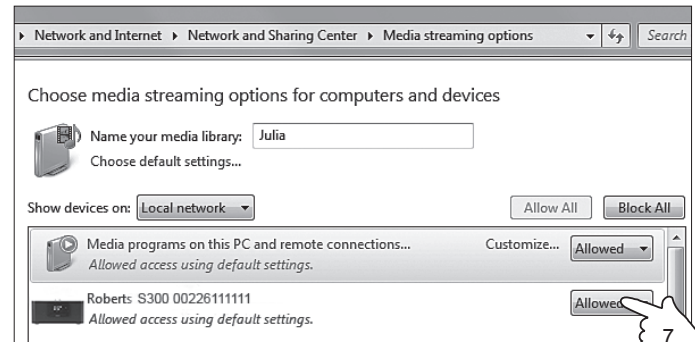



## Locating and playing media files using UPnP

Once the UPnP server has been configured to share media files with your sound system, you may select the files that you wish to play as follows:-

1. Press the **On/Standby** button to switch on the unit. Press the **Media** button as needed until the *Music Player* mode display is shown. The main Music Player menu will then be displayed.
  2. Press the **Menu Up** or **Down** buttons until 'Shared media' is highlighted on the display and then press the **Select** button to cause the sound system to scan for UPnP servers. Note that it may take a few seconds for the sound system to complete its scan. The display will return to the Music Player menu if no UPnP servers are found.
  3. After a successful scan, press the **Menu Up** or **Down** buttons to highlight your UPnP server and then press the **Select** button. If the display shows multiple media types, select '*Music*'. (Some UPnP servers can serve pictures and video content to suitable devices.)
  4. The sound system will now list the media categories which are made available by the UPnP server - for example, '*Album*', '*Artist*' and '*Genre*'. Press the **Menu Up** or **Down** buttons to highlight which category you wish to browse, then press the **Select** button to confirm your choice.
- If you wish to use the search function Press the **Menu Up** or **Down** buttons until '*Search*' is selected on the display. You may select characters to build a keyword for searching for content to play.

When you first set up sharing with a UPnP server, not all of your files will be available immediately. The UPnP server must look inside each file to identify the artist and album information from 'tags' embedded in them. The server may also need time to access the Internet to obtain additional information such as 'album art' which it can display when you examine your music library on your PC. For a library of many files this can take some time.

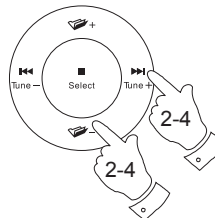
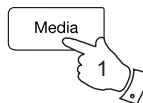

## Music Player

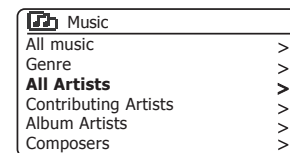
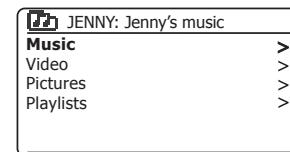
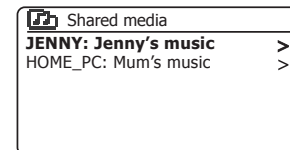
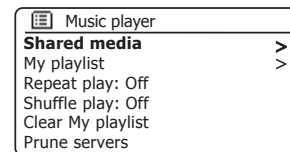
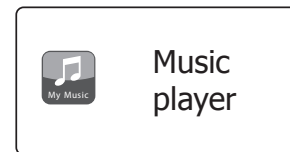

## Media selection

When searching via UPnP you will have a selection of search criteria as determined by the UPnP server software on your computer. This allows you to search by a given information type (Album, Artist, Genre, etc.) and then to narrow the search to an album or to a particular track within an album.

Some UPnP server applications allow the search options to be customised. The searches described here are just examples of the possibilities.

## Listening to a complete album

1. Press the **Menu Up** or **Down** buttons to choose content by Artist, Album, Genre, etc. according to your needs then press the **Select** button to enter your choice.
2. When you reach the album or folder the menu will then switch to showing the tracks in that album or folder. When searching by UPnP they will normally be listed in track number order (but as with the search criteria, this can vary according to the server application used).
3. With the first track in the album indicated, press the **Select** button. The album will then begin playing.

While the sound system is playing from your media library, you may use the menus as described above to choose a different selection. When you select the track from which to play, the sound system will then immediately begin playing the new selection.

Please also see 'Playlists' on page 59.

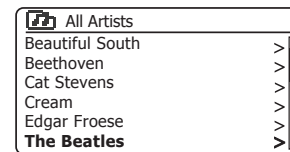
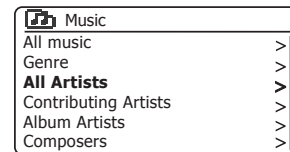
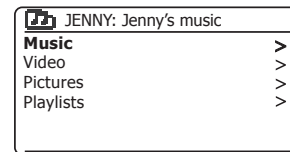
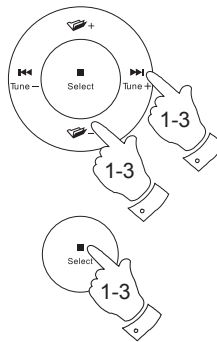

## Listening to a particular track

1. If you wish to play only a particular track from an album or folder, first choose the album or folder as described on the preceding pages.
2. Press the **Menu Up** or **Down** buttons until the required track is highlighted.
3. Press and release the **Select** button. The track will begin playing. The sound system will then play subsequent tracks from the same album or folder.

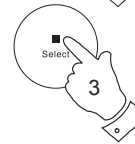
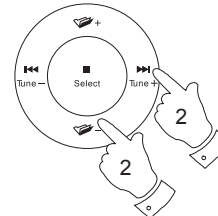

## Controlling playback

1. Press the **Play/Pause** button to pause playback of the current track.
2. If you press the **Play/Pause** button, playback will resume from the point where it was paused.
3. Press the **Previous** button to start playback of the previous track in the list.
4. Press the **Next** button to start playback of the next track in the list.
5. Press and hold the **Next** or **Previous** button to move through the current track. The longer the button is pressed, the greater the speed at which the player will move through the track. Release the button when the desired point is reached. (Note that this feature is not supported when playing files encoded using the FLAC format.)
6. Press the **Stop** button to stop playback.

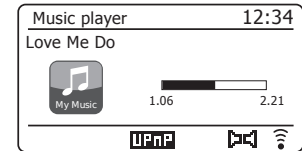
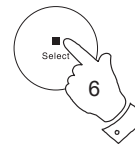
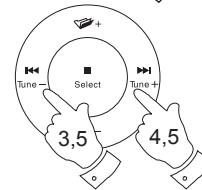
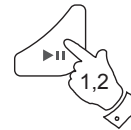

## Controlling playback cont.

In the music player you may choose to repeat the current album (or playlist), or to play the files in random order, or both options together.

### Repeat tracks

1. To enable or disable the Repeat option, press and release the **Repeat** button on the remote control. The **Repeat** icon will show on the display when Repeat is enabled.

You may also control the option from the Main Music Player menu.

2. Press the **Menu Up** or **Down** buttons until *'Repeat play'* is highlighted.
3. To activate the repeat option press and release the **Select** button so that *'On'* appears on the display.
4. To turn off the repeat option highlight *'Repeat play'* and press and release the **Select** button so that *'Off'* appears on the display.
5. Press the **Back** button to exit from the menu.

### Play tracks in random order

1. To enable or disable the Shuffle option, press and release the **Random** button on the remote control. The **Shuffle** icon will show on the display when Shuffle is enabled.

You may also control the option from the Main Music Player menu.

2. Press the **Menu Up** or **Down** buttons until *'Shuffle play'* is highlighted.
3. To activate the shuffle option press and release the **Select** button so that *'On'* appears on the display.
4. To turn off the shuffle option highlight *'Shuffle play'* and press and release the **Select** button so that *'Off'* appears on the display.
5. Press the **Back** button to exit from the menu.

If both Repeat and Shuffle playback options are set to *'On'* then both Repeat and Shuffle icons will be shown in the display.

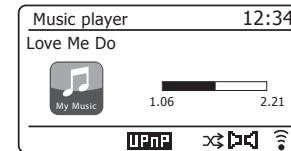
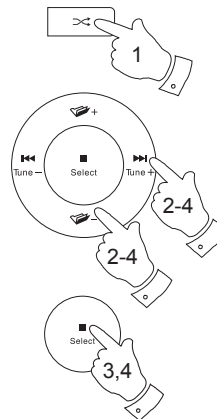
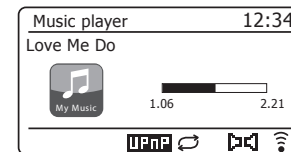
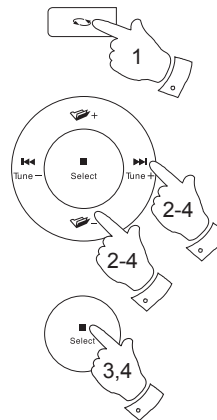

## Display modes

Your sound system has a range of display options when in *Music Player* mode. Note that the availability of information depends on the specific media files, their format and upon the server capability. (Not all UPnP servers make information from the media files available in the same way.)

1. Press and release the **Info** button to cycle through the different options.

- |                 |   |
|-----------------|---|
| a. Progress bar | Displays the playback progress for the track currently playing.   |
| b. Artist       | Displays the artist information for the track currently playing.  |
| c. Album        | Displays the album information for the track currently playing.   |
| d. Format       | Displays the bit rate and format of the track currently playing.  |
| e. Buffer       | Displays the radios internal buffer status during media playback. |
| f. Date         | Displays the current date.  |

Whenever the Music Player is displaying an information screen (as opposed to a menu screen), the time is displayed in the top-right corner of the display, and a WiFi strength or Ethernet connection indicator is shown in the bottom-right corner together with an indicator showing the method by which the radio is obtaining the media - from a UPnP server.

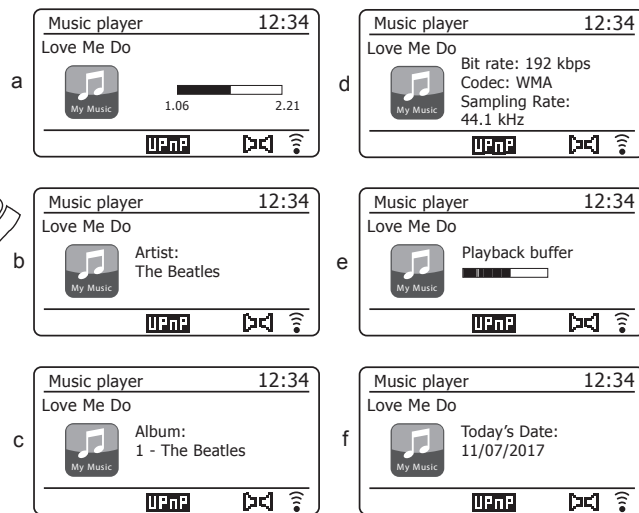
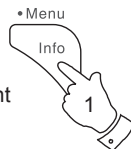

The S300 is able to display the album art for the track being played. The ability of the sound system to display art depends on the presence of the art in the file being played, the art being not too large (or being re-sized by the server), and the ability of the UPnP server to send the art to the radio. Art sent to the sound system needs to be in a JPEG format and no larger than 640 x 480 pixels. If the unit does not receive any art then a default icon is displayed. Some UPnP server applications will also send a default icon if no art is found within the file being played. Some UPnP server applications will be able to re-size the art, if needed, before sending it to the sound system. If the unit expects to receive art but none is provided then no art or icon will be displayed. Due to the wide variations in album art formats and UPnP/DLNA standards, the failure of the unit to display album art is not considered to be a fault.

## Playlists

Sometimes you may wish to set up a list of music tracks or albums which can then be played without further action - as background music for a party, for example.

Your sound system can be configured to hold a queue of up to 500 tracks in a playlist menu. The tracks or albums for the playlist can be selected from your UPnP server. The playlist is held in the memory in your sound system until the external power is removed, or until the playlist is cleared from the menu.

### Adding a single track to your playlist

1. When selecting (or when playing) a track using a UPnP server **press and hold** the **Select** button and the display will show '*Added to My playlist*'.
2. The track will be added to the playlist for playback later.

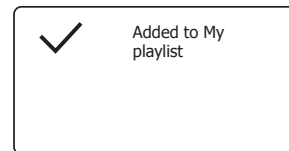
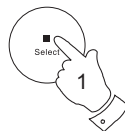

### Adding an entire album or folder

3. When using a UPnP server highlight the chosen album, artist or folder and **press and hold** the **Select** button. The display will show '*Added to My playlist*'.
4. Each of the tracks within the album, artist or folder selection will be added to the playlist individually. This allows any unwanted tracks to be removed from the playlist if needed (see the next page).

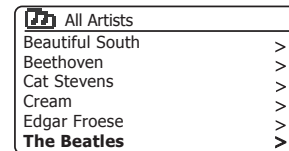
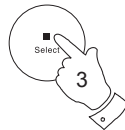

## Viewing your playlist

1. Press the **On/Standby** button to switch on the unit. Press the **Media** button as needed until the *Music Player* mode display is shown. The Music Player menu will then be shown on the display.
2. Press the **Menu Up** or **Down** buttons until 'My Playlist' is highlighted on the display. Press and release the **Select** button to enter the playlist.
3. Press the **Menu Up** or **Down** buttons to scroll through the playlist. Tracks which are served via UPnP will show their track name.

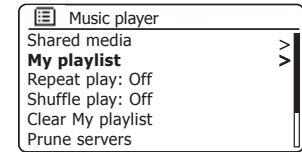
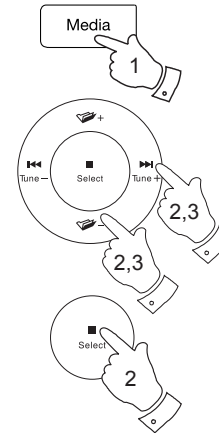

## Erasing a track from the playlist

1. **Press and hold** the **Menu** button to enter the main Music Player menu.
2. Press the **Menu Up** or **Down** buttons until 'My Playlist' is highlighted on the display. Press and release the **Select** button to enter the playlist.
3. Press the **Menu Up** or **Down** buttons until the track you wish to erase is highlighted. **Press and hold** the **Select** button.
4. You will be asked to confirm the deletion. To delete the track press the **Menu Up** or **Down** buttons until 'YES' is highlighted on the display then press and release the **Select** button to confirm the deletion.
5. If you do not wish to delete the track from the list, press the **Menu Up** or **Down** buttons to highlight 'NO' and press and release the **Select** button to cancel the operation.

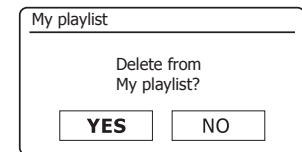
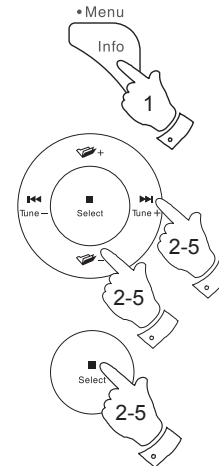

## Clearing the playlist

1. **Press and hold** the **Menu** button to enter the main Music Player menu.
2. To clear the whole playlist press the **Menu Up** or **Down** buttons until 'Clear My playlist' is highlighted on the display. Press and release the **Select** button.
3. To clear the whole playlist press the **Menu Up** or **Down** buttons until 'YES' is highlighted on the display. Press and release the **Select** button to clear the playlist.
4. If you do not wish to clear the playlist press the **Menu Up** or **Down** buttons to highlight 'NO' and press and release the **Select** button to confirm.

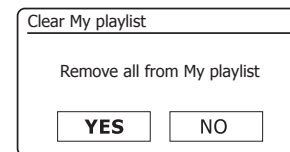
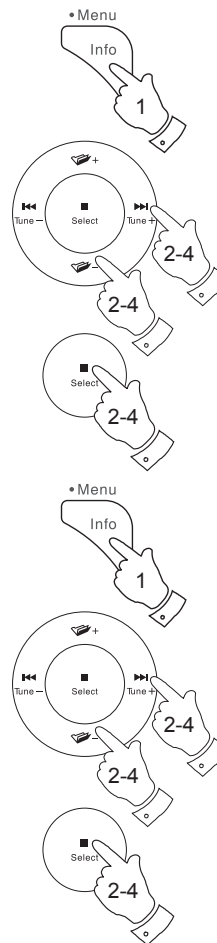

## Playing your playlists

1. **Press and hold** the **Menu** button to enter the main Music Player menu.
2. Press the **Menu Up** or **Down** buttons until 'My playlist' is highlighted on the display. Press and release the **Select** button.
3. To play the playlist from a particular track, press the **Menu Up** or **Down** buttons until the desired track is highlighted then press and release the **Select** button to start play.
4. While playing from the playlist, you can use this function to jump to a particular track within the playlist.
5. While playing from the playlist, you may add additional tracks or albums or remove specific tracks (please see the preceding pages).

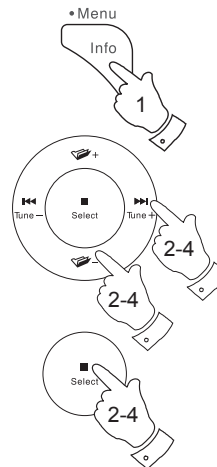



## Prune servers

Your sound system stores details of UPnP servers that it has seen via its network connection in its internal memory. If you use the sound system at different locations you may find that there are servers listed by the sound system that you are no longer interested in. The prune servers functions allows the list to be updated so that only active UPnP servers on the currently connected network are shown when selecting 'Shared Media' from the Music Player menu.

1. **Press and hold** the **Menu** button to enter the main Music Player menu.
2. Press the **Menu Up** or **Down** buttons until '**Prune servers**' is highlighted on the display. Press and release the **Select** button.
3. To remove servers that are no longer required press the **Menu Up** or **Down** buttons until '**YES**' is highlighted on the display. Press and release the **Select** button to cause the servers to be removed.
4. If you do not wish to prune servers press the **Menu Up** or **Down** buttons to highlight '**NO**' and press and release the **Select** button to confirm.

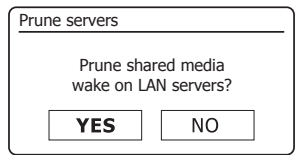
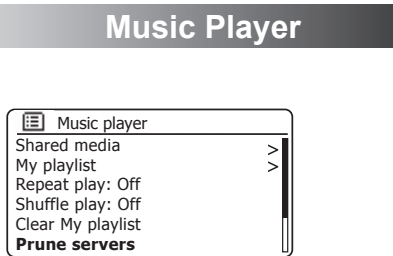
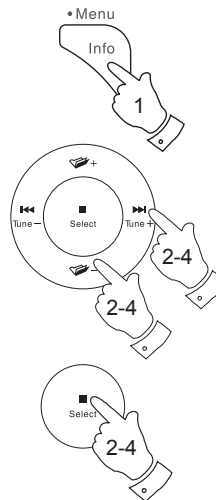

## Windows 'Play to' / 'Cast to Device' function

If you use Windows 7, 8, 8.1 or 10 it is possible to choose a music album, track or playlist at the computer and then tell Windows that this should be played on the sound system using the 'Play to' function (called 'Cast to Device' in Windows 10).

Similar functionality is available for other computer types and for handheld devices using Apple's iOS or Android operating systems. In this mode the sound system operates as a Digital Media Renderer (known as DMR mode).

1. Ensure your sound system is plugged in and connected to your network.
2. At your windows PC, locate the file, album or playlist that you wish to play on the sound system.
3. Use the right-hand mouse button to pop-up a menu of options for the chosen item and select the 'Play to' / 'Cast to Device' option.
4. Windows should show you one or more devices, including your sound system, to which you may choose to send the music. Highlight the sound system item and click with the left mouse button.
5. Windows will then open a 'Play to' / 'Cast to Device' window showing the track or tracks to be played. Your computer will then take control of your sound system. Your sound system will enter the Digital Media Renderer mode (DMR) and after a few seconds the sound system will start playing. The display on the sound system will show that it is in DMR mode.

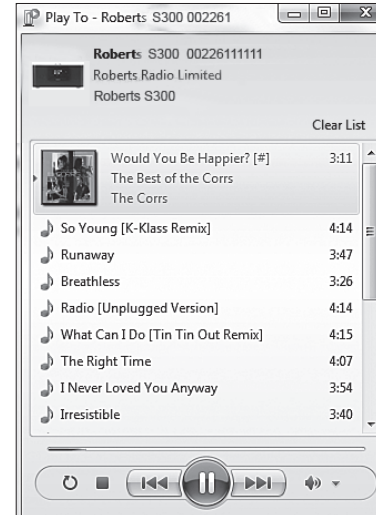

6. While the sound system is playing in DMR mode you can use the controls in the 'Play to' / 'Cast to Device' window on your computer to skip tracks, fast-forward or rewind, to pause or restart, and to change the volume on the sound system.

You may also use the controls on your sound system to adjust volume, display track information (press the **Info** button) or to change operating mode. It is not possible to skip tracks or pause playback using the sound system's controls while it is in DMR mode.

7. While playing, you may select additional content within Windows and again use the 'Play to' / 'Cast to Device' function (see steps 2 – 4). The additional tracks will be added to the playlist in the current 'Play to' / 'Cast to Device' window. You may also delete or change the order of tracks within the 'Play to' / 'Cast to Device' window.

8. When you wish to exit DMR mode, simply either switch off your sound system or select a different operating mode.

**Note:** Some Windows security software can prevent correct operation of the 'Play to' / 'Cast to Device' function. Such software may have updates or configuration options which will permit 'Play to' / 'Cast to Device' to operate correctly - please consult your anti-virus software supplier. The 'Play to' / 'Cast to Device' function in Windows 7, 8 and 10 has been tested successfully with the S300 when using Microsoft's own security software without problems.

## Music Player

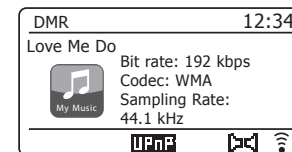
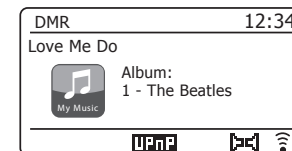
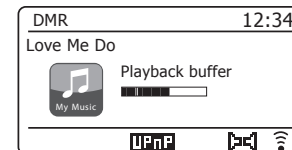

# Spotify Connect

## Spotify Connect - the basics

Spotify is all the music you'll ever need. Millions of songs available instantly. Just search for the music you love, or let Spotify play you something great. Spotify works on your phone, tablet, computer and home speakers. So you'll always have the perfect soundtrack for whatever you're doing.

Spotify Connect allows your Spotify selections to be played through the sound system, remotely controlled from your iPhone, iPad, Android device or any Desktop.

Spotify Connect also allows you to transfer the playing of the sound to other Spotify Connect enabled devices under the control of your smart-phone, tablet or any Desktop

Once your Spotify account has been connected to your sound system, you may start Spotify playing from the sound system without needing to use the Spotify app.

Spotify Connect compatibility is shown with the following identifier:



## Setting up Spotify Connect

For more details about setting up Spotify Connect, please go to [\*\*spotify.com/connect\*\*](https://www.spotify.com/connect)

To use Spotify with your S300 sound system you will need to download the Spotify app and you will need a **Spotify Premium** account.

The Spotify software is subject to third party licenses found here: [\*\*www.spotify.com/connect/third-party-licenses\*\*](https://www.spotify.com/connect/third-party-licenses)

## Using Spotify Connect

1. Add your S300 to your network using WiFi or Ethernet, see '*Configuration*', page 10.
2. Fire up the Spotify app on your phone, tablet or PC using the same network as above.
3. Play a song on Spotify and hit '*Devices available*'.
4. Choose your S300 sound system and your music will start playing out loud.

More complete instructions for using Spotify Connect with the sound system are given on the following pages.

**Note: The recording feature is not available when using Spotify Connect.**

## Playing music using Spotify Connect

Spotify Connect lets you push a button to control the music between your Spotify Connect enabled devices. While playing a song, you can switch playback from your smart-phone, tablet, Desktop or even to a Connect enabled radio.

1. Ensure your sound system is plugged in and connected to your network.
2. Make sure that both your sound system and Apple iOS / Android device are connected to the same network and that you have downloaded the latest Spotify app on your device.
3. Simply open the Spotify app on your Apple iOS / Android device and choose a track or playlist. When the Spotify app has identified other devices that are compatible with Spotify Connect, the **Spotify Connect icon** (🔊) will be shown with the text '*Devices available*'.  
  
Tap the **Spotify Connect icon** (🔊) or the '*Devices available*' text to show a list of Spotify Connect enabled devices to which you can transfer the playing of the music.
4. To select your sound system choose **S300** on the Spotify Connect devices screen. You are now ready to play music through your sound system using Spotify Connect. The Spotify app will also allow remote control of the volume and track selection.

The next time you open Spotify, it will continue playing from the previously selected device.

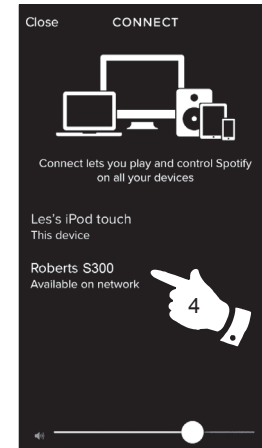
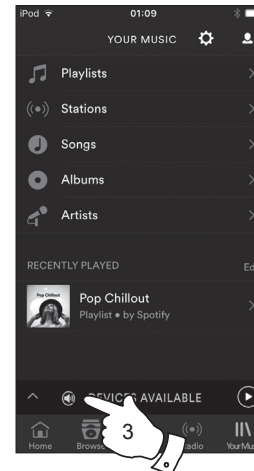

Note: On some devices the layout of controls within the Spotify app may be different from that shown and may also change with different versions of the app. Refer to [spotify.com/connect](https://spotify.com/connect) if needed.

## Controlling Spotify on your sound system

The music can be controlled using the controls on your sound system as well as by any Spotify enabled device.

1. Press and release the **Play/Pause** button to pause playback of the current track.
2. Press and release the **Play/Pause** button, playback will resume from the point where it was paused.
3. Press the **Next** button to start playback of the next track in the current Spotify playlist.
4. Press the **Previous** button to start playback of the previous track in the current Spotify playlist.
5. Press the **Volume Up** or **Down** buttons to set the required volume level. The volume may also be controlled from within the current Spotify app.

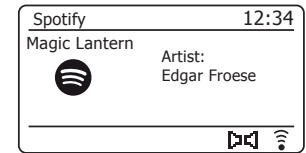
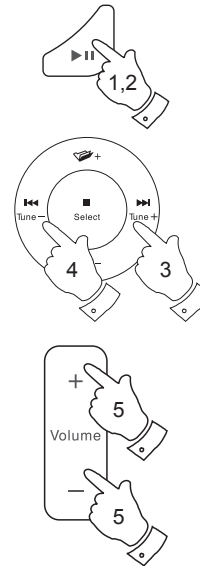

## Using the Radio button to select Spotify

If you have previously connected using the Spotify Connect app you may select Spotify using the Radio button on your sound system.

1. Press the **Radio** button to select the Spotify mode.

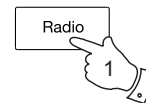

Please note if the power is removed you will need to re-connect Spotify with your sound system using the app once again.

## Display modes - Spotify Connect

Your sound system has a range of display options when playing Spotify Connect.

1. Press the **Info** button to cycle through the different options.

- |                           |   |
|---------------------------|---|
| a. Progress bar           | Displays the playback progress for the track currently playing.         |
| b. Artist                 | Displays the name of the artist for the track currently playing.        |
| c. Album                  | Displays the name of the album from which the current track is taken.   |
| d. Bit rate               | Displays the bit rate and sampling rate of the track currently playing. |
| e. Playback buffer level. | Displays the sound system's internal buffer level.                      |

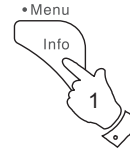

## Spotify Connect

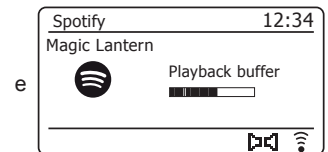
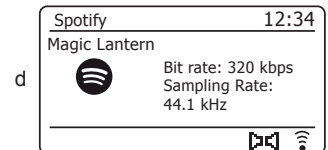
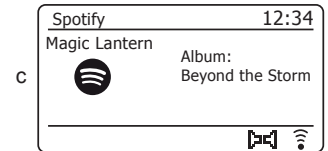
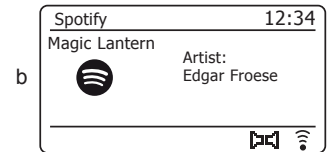
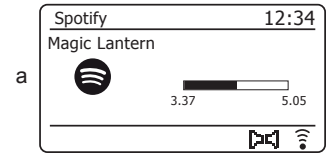

Whenever the sound system is displaying an information screen, the time is displayed in the top-right corner of the display, and a WiFi strength or Ethernet connection indicator is shown in the bottom-right corner.

## Bluetooth mode

The Bluetooth mode on your sound system allows you to play audio, play sound from video files and stream music from Bluetooth capable devices such as your mobile phone, computer, tablet etc. through your sound system's loudspeakers.

- When a Bluetooth enabled device such as your S300 sound system is in a discoverable state other Bluetooth devices can detect, pair with or connect to it.
- 'Bluetooth pairing' occurs when two Bluetooth enabled devices agree to establish a connection and communicate with each other.

## Connecting Bluetooth devices

1. Ensure that the Bluetooth capability on your phone, tablet or PC is enabled.  
You may need to refer to the user documentation for your device, since the method will vary with each device.
2. Press and release the **On/Standby** button to switch on the sound system.
3. Press the **Media** button on your sound system until the Bluetooth mode is selected. Your sound system will show that it is discoverable and will show 'Connecting...' on the display.
4. Using the Bluetooth settings of your phone, tablet or PC direct it to search for discoverable devices. After a few seconds, you should see a device named 'S300'. Just occasionally it may take longer for the sound system to be found by your device.
5. Select 'S300' to cause your phone, tablet or PC to pair with your sound system and to establish a connection.
6. Once the connection is established, a message will be displayed confirming the name of the connected device.

You can now begin playing music from your smart-phone, tablet, etc.

Some Bluetooth devices may require a 'Passkey' (an authentication key) in order to establish a link between devices. A passkey is similar to a password, although you only need to use the passkey once to establish a link. If your device asks for a passkey to be able to pair with your sound system then enter a code of 0000 (four zeroes).

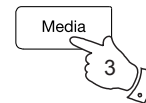



## Playing audio files in Bluetooth mode

When you have successfully connected your sound system with your chosen Bluetooth device you can start to play your music using the controls on the device.

1. Once playing has started adjust the volume to the required setting using the **Volume** buttons on your sound system or the connected Bluetooth device.
2. The volume of your sound system in Bluetooth mode is affected by the volume settings on the sound system and also on the connected Bluetooth device.

If you adjust the volume control on the sound system but you find that the volume from the sound system is not sufficient, it may be that the volume setting of the connected device needs to be increased.

3. The audio player in your phone, tablet or PC may be able to respond to the **Play/Pause**, **Next** track and **Previous** track buttons on the sound system.

**Note:** That not all player applications or devices may respond to all of these buttons.

4. If your connected device is able to provide information from the track being played, you may press and release the **Info** button to display the Title, Album and Artist details on the display.

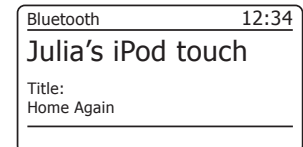
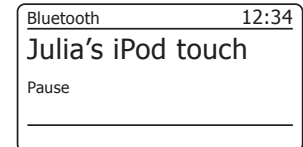
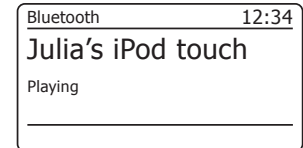
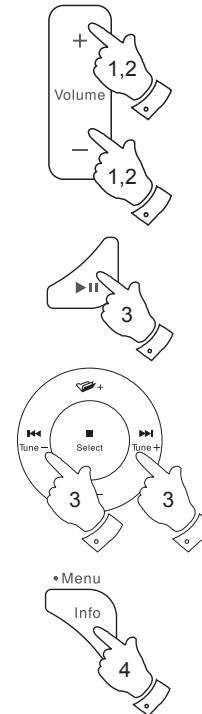

## Connecting and reconnecting a Bluetooth device

You can only have one Bluetooth device connected to the sound system at any one time although it may be paired with several devices. Once you have a Bluetooth enabled device connected to your sound system it cannot be interrupted by another Bluetooth device unless you choose to break the connection.

1. To connect to a different device, **press and hold** the **Menu** button on the sound system to access the menu options.

Press the **Menu Up** or **Down** buttons until **'Paired devices'** is highlighted. Press and release the **Select** button.

2. The sound system will then display a list of previously connected devices. Press the **Menu Up** or **Down** buttons to step through the list.

To connect to a previously paired device, press and release the **Select** button when the device's name is highlighted. In some cases you may also need to re-enable the connection from your device's Bluetooth settings. The sound system will then connect to the device.

3. To connect to a new device, **press and hold** the **Back** button or select **'Connect device'** from the menu. **'Pairing'** will show on the display. The sound system will become discoverable by other devices.

4. You can now pair the sound system with the new device using its Bluetooth settings (the sound system will be listed as **'S300'**). The name of the newly connected device will be briefly shown on the sound system's display. You may then play music from the new device through the sound system.

5. If you no longer want your Bluetooth device to be paired with your sound system you will need to delete the **'S300'** pairing on the device. Please refer to the device's Bluetooth documentation.

6. If you wish to forget all paired bluetooth devices, press and hold the **Menu** button. Press the **Menu Up** or **Down** buttons until **'Forget devices'** is highlighted. Press and release the **Select** button, select **'YES'** and all currently paired devices will be deleted.

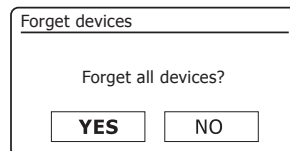
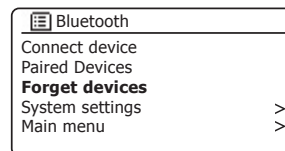
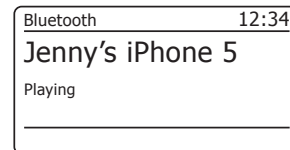
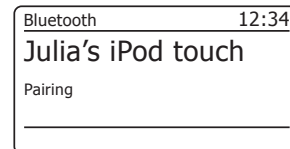
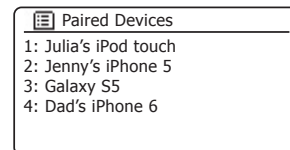
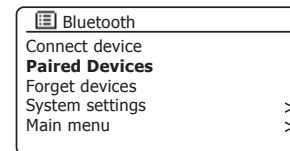
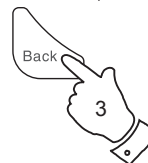
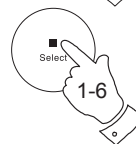
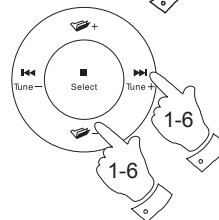
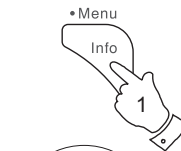

## Bluetooth Information

Bluetooth connectivity performance may vary depending on the connected Bluetooth devices. Please refer to the Bluetooth capabilities of your device before connecting to your sound system. All features may not be supported on some paired Bluetooth devices.

A Bluetooth connection can provide a link for audio up to a distance of approximately ten metres. When pairing two Bluetooth enabled devices, for convenience, we recommend they should be no more than 2 to 3 metres apart. The presence of other functioning Bluetooth devices during connection may lead to operational difficulties.

Bluetooth is a short-range radio communication system and generally Bluetooth devices can communicate with each other clearly within a regular sized room or office. The reliability of a Bluetooth connection between different rooms will greatly depend upon the construction of the building.

Bluetooth communication range may be substantially reduced if the signal passes through a solid object. Human bodies, brick and concrete walls, heavy furniture or bookcases will all reduce the operational range of your Bluetooth devices to a greater or lesser extent. Glass, dry-wall or wood paneled walls and office partitions may have a less severe but noticeable effect. Metal pipes, foil-lined plasterboard, metal window frames and domestic wiring can also have an effect. You should position your Bluetooth devices closer to each other if you observe communication difficulties.

## Bluetooth pairing your device by NFC

Your sound system is equipped with a wireless NFC (Near Field Communication) feature (located on the front panel of your sound system) allowing other NFC enabled devices to pair and play music with your sound system.

1. Ensure that Bluetooth and NFC are enabled on your device. You may need to refer to the user documentation for your device, since this method will vary with each device.

WiFi networks and cordless phones generally use similar radio frequencies to Bluetooth and may interfere with one another. If any interference is noticed, then try relocating the sound system or one of the other devices.

The Bluetooth capabilities of your sound system enable it to receive audio from many Bluetooth capable devices including mobile phones, personal computers and tablets. Only one Bluetooth device can be connected to your sound system at a time. It supports the following Bluetooth profiles and functionality.

- Your sound system supports A2DP (Advanced Audio Distribution Profile) which is a stereo audio connection that streams stereo music from PCs, mobile phones etc. SBC and AAC audio codecs are supported.
- Your sound system supports AVRCP (Audio Video Remote Control Profile) which allows your sound system to control music playback from the connected device.

**Note:** Some mobile phones may temporarily disconnect from your sound system when you make or receive calls. Some devices may temporarily mute their Bluetooth audio streaming when they receive text messages, emails or for other reasons unrelated to audio streaming. Such behaviour is a function of the connected device and does not indicate a fault with your sound system.

## Compact discs

Use only Digital Audio CDs which have the  symbol.

**Use only full size CDs (12cm diameter) with the sound system. Mini CDs (8cm diameter) are not compatible with the player and may jam the CD mechanism.**

Transparent or partly transparent CDs cannot be played since they may not be detected when inserted. Unusually thin (Eco) CDs cannot be played. Some copy-protected CDs may not be playable.

Never write on a CD or attach any sticker to the CD. Always hold the CD at the edge and store it in its box after use with the label facing up.

To remove dust and dirt, breathe on the CD and wipe it with a soft, lint free cloth in a straight line from the centre towards the edge.

Cleaning agents may damage the CD.

Do not expose the CD to rain, moisture, sand or to excessive heat. (e.g. from heating equipment or in motor cars parked in the sun).

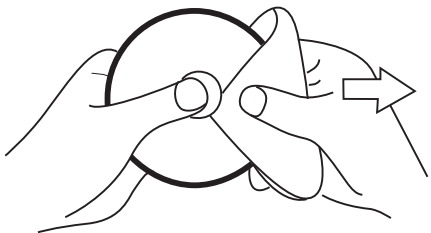

## CD-R/CD-RW discs

Your S300 sound system can playback CD-DA format audio CD-R/CD-RW discs that have been finalised\* upon completion of recording.

\*Finalising enables a CD-R/CD-RW disc to playback on audio players such as your sound system. A disc which has not been finalised may have information added to it using a computer but may not always be playable. You may have to specifically enable the finalising step with some CD writing software.

Your sound system may fail to play some CD-R/CD-RW discs due to poor recording and wide variation in quality of the CD-R/CD-RW disc.

## Inserting a CD

Ensure the CD player is empty before inserting a disc. If there is a disc in the player then the CD Eject button will be lit. If you cannot insert a disc, press the **CD Eject** button to remove the CD currently in the player.

1. Press and release the **On / Standby** button to switch on your sound system.
2. To select the CD mode press the **Media** button until 'CD' shows on the display or insert an audio CD.
3. To eject a CD press and release the **CD Eject** button. To reload a CD that has just been ejected, press the **Eject** button a second time.
4. Insert a disc with printed side facing up into the CD slot. The disc will be loaded automatically. The unit will check the CD type and load its track list. The display will show 'Loading' and then 'Reading' as the information is read.
5. If you load a disc containing MP3 or WMA files your sound system will enter the MP3 / WMA mode (see page 78).

## Playing a CD

1. Press the **Play / Pause** button to start playing the disc. The display will show the first track number.
2. Adjust the **Volume** to the required setting.
3. To pause playing press the **Play / Pause** button. To resume press the **Play / Pause** button again.
4. To stop playback, press the **Stop** button.
5. If you put the unit into standby mode then the next time the unit is switched on it will return to the previously played track.

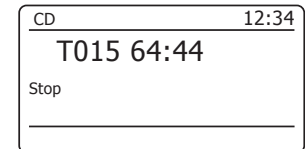
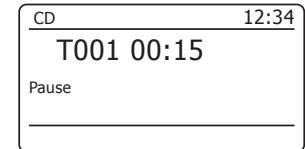
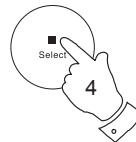
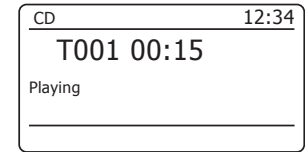
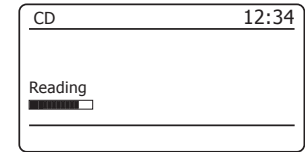
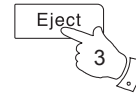
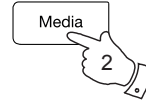

## Ejecting a CD

1. To take out the CD, press and release the **CD Eject** button. The display will show 'Eject'. In order to protect the disc if it is not removed, the unit will reload the CD after 10 seconds and then enter standby mode.
2. In the event that the CD fails to eject, *press and hold* the **CD Eject** button. This will cause the CD player to eject the disc even if it is unable to detect the presence of an inserted CD (as may happen if the CD has a large area of transparency).

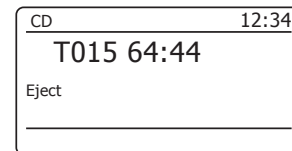
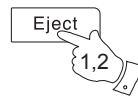

## Selecting a track

1. While the CD is playing, press either the **Next** or **Previous** buttons to change to the desired track. The updated track number is shown in the display.
2. You can also skip tracks when the player is paused or stopped. Skip to the desired track using the **Next** or **Previous** buttons, release the button when the desired track is displayed.
3. Press the **Play / Pause** button to play the selected track.

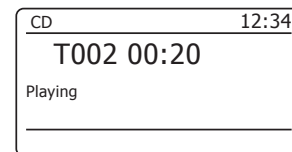
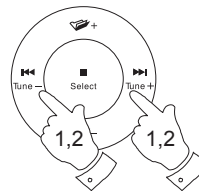

## Selecting a track

1. For track numbers 1-9 simply press the corresponding digit button on the remote control. For track numbers ten and above press the required digits using the 10/0 button to enter the digit zero.
2. If the track number exceeds the number of tracks on the CD, then the last track on the CD will be played.

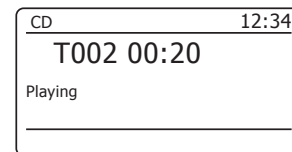
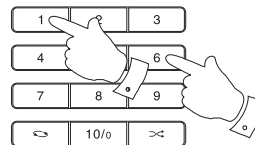

## Search function

1. While the CD is playing, press and hold the **Next** or **Previous** buttons. Release the button when the desired part of the track is reached.

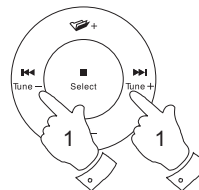

## Repeat a single track

1. While the CD is playing, press the **Repeat** button (on the remote control) until the repeat single track symbol (  ) appears in the display. The current track will be repeated.

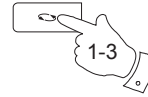

## Repeat all tracks

2. While the CD is playing, press the **Repeat** button (on the remote control) until the repeat all tracks symbol (  ) appears in the display. All of the tracks on the CD will be played repeatedly.

## Play tracks introduction

3. While the CD is playing, press the **Repeat** button (on the remote control) until the track introduction symbol (  ) appears in the display. The first 10 seconds of each track will be played. When the desired track is reached, press the **Repeat** button once more to revert to normal play mode.

## Shuffle tracks

4. While the CD is playing, press the **Random** button (on the remote control) until the shuffle symbol (  ) appears in the display. The tracks will be shuffled. To cancel the shuffle function, press the **Random** button a second time.

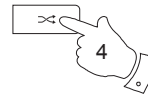

Alternatively the repeat and shuffle options are available when using the menus.

## CD track programming

In addition to playing of complete CDs, selected tracks, or a random selection, the CD player allows you to programme a sequence of up to 20 tracks to be played in whatever order you choose.

1. With the unit in CD mode and with a CD inserted, make sure that the CD is stopped (press the **Stop** button).
2. To enter programming mode, press the **Auto Tune** button (on the remote control).
3. Choose the first track using the **Next** or **Previous** buttons.
4. Press the **Auto Tune** button to enter the selected track into the programme.
5. Choose another track using the **Next** or **Previous** buttons, and enter it into the programme using the **Auto Tune** button (track 10 in example shown).
6. Repeat step 5 to store as many as 20 tracks in the programme.
7. When the programme is complete, press the **Play / Pause** button to start playing. The tracks will then be played in the order that you have just programmed.
8. The programme will be erased when the CD is removed.

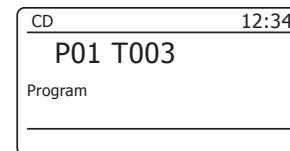
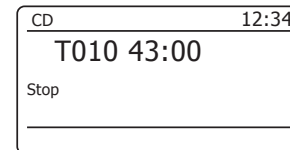
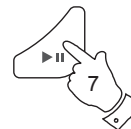
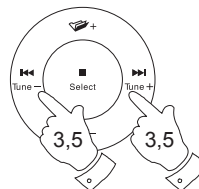

**Note:** If you are programming the tracks using a CD with MP3 or WMA files in folders (see the following pages), you can also use the **Up** or **Down Folder** buttons to specify the folder in steps 3 and 5 above.



## MP3/WMA CD Mode

The S300 sound system is able to play CD-R and CD-RW discs containing MP3 and WMA files. It is assumed in this section that a file is equivalent to a CD track.

An MP3 / WMA CD may not contain more than 511 files and not more than 99 folders. MP3 and WMA files should be created with an audio sample rate of 44.1kHz (this is normal for files created from CD audio content). MP3 and WMA data rates up to 320 kilobits per second are supported. WMA Lossless, WMA Voice, WMA 10 Professional and files which have DRM protection are not supported.

When burning CD-R and CD-RW discs with audio files, various problems may arise which could lead to problems with playback. Typically such problems are caused by poor CD writing or audio encoding software, or by the hardware settings of the PC's CD writer, or by the CD being used. Should such problems arise, contact the customer services of your CD writer or software manufacturer or look in their product documentation for relevant information. When you are making audio CDs, take care to observe all legal requirements and ensure that the copyright of third parties is not infringed.

1. To select the CD mode press and release the **Media** button until 'CD' shows on the display, or insert a suitably prepared CD-R or CD-RW disc.
2. Insert a CD with printed side facing up into the CD slot. The disc will be loaded automatically. The unit will check the CD type and load its track list. The display will show '*loading*' and then '*reading*' as the information is read.

If there are many files or folders on the CD then it may take some tens of seconds to read all of the file and folder names and to identify those which are playable (with .mp3 or .wma filename extension).

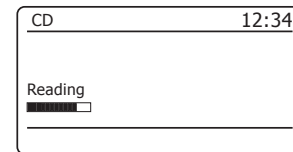
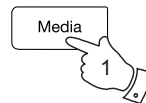

## Playing an MP3/WMA CD

1. Press the **Play/Pause** button to start playing from the CD. The display will show the first folder and file numbers - '01' and '001'.
2. To pause playing press the **Play / Pause** button. To resume playing press the **Play / Pause** button again.

If you put the unit into standby mode then the next time the unit is switched on it will return to the previously played file.

3. To Stop playback, press the **Stop** button.
4. To take out the CD, press the **CD Eject** button. The display will show 'Eject'. In order to protect the disc if it is not removed, the unit will reload the disc after 10 seconds and then enter standby mode. To reload a CD that has just been ejected, press the **Eject** button a second time.

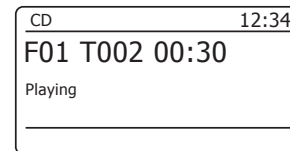
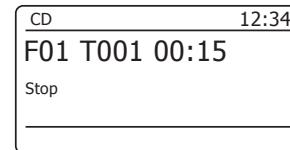
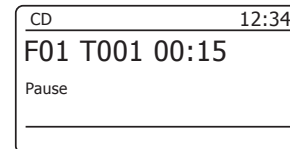
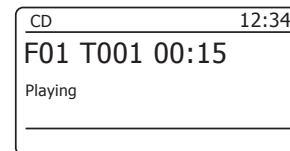
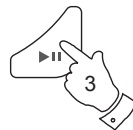
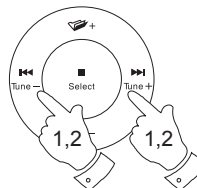
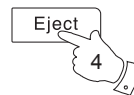
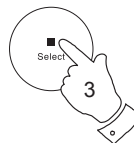

## Selecting a file

1. While the CD is playing, press either the **Next** or **Previous** buttons to change to the desired file, the file number is updated in the display. If there is more than one folder, when all files in the current folder have been played the next folder will be played.
2. You can also skip files when the player is in stop mode. Skip to the desired file using the **Next** or **Previous** buttons and release the button when the desired file number is displayed.
3. Press the **Play / Pause** button to play the selected file.

## Select a specific file

- For file numbers 1-9 simply press the corresponding digit button on the remote control. For file numbers ten and above press the required digits using the 10/0 button to enter the digit zero.
- If the file number entered exceeds the number of playable files on the CD, then the last file will be played.

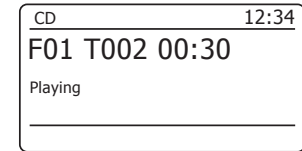
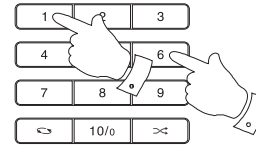

File numbers up to 512 may be entered. The numbers of files in folders are added together. So, for example, if the first two folders each contain 10 files, then entering 15 will play the fifth file in the second folder.

## Search function

- While the MP3 / WMA CD is playing, press and hold the **Next** or **Previous** buttons. Release the button when the desired part of the current file is reached.

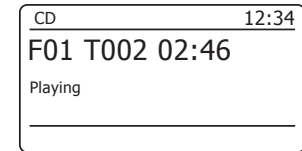
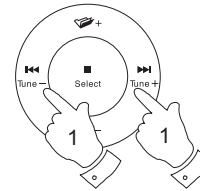

## To skip to another folder

- With the MP3 / WMA CD in stop or play mode, press and release either the **Folder Up** and **Down** buttons. The first file of the next or previous folder will be played.

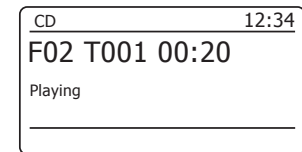
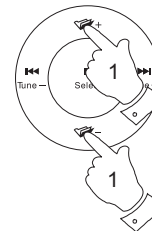

## Repeat, Intro, shuffle and Programmed play

The S300 allows you to use the same playback options for files as can be used for conventional CDs (see pages 74-77). In addition to repeat a single file and repeat all options, there is also a repeat folder facility.

## Display modes

Your sound system has a range of display options when in MP3 / WMA CD mode. Note that not all information may be available for all files.

1. Press and release the **Info** button to cycle through the different options.
  - a. Progress Displays the playback progress for the track currently playing.
  - b. File name Displays the file name and audio format of the track currently playing.
  - c. Album Displays the name of the album from which the current track is taken.
  - d. Artist Displays the name of the artist for the currently playing track.
  - e. Title Displays the title of the currently playing track.

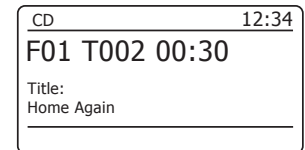
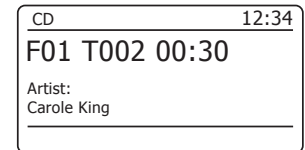
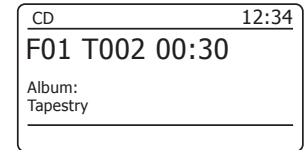
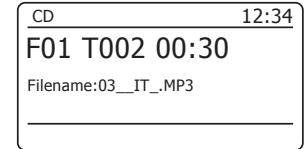
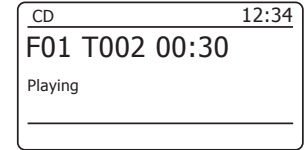
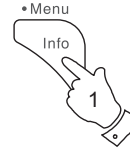

## Using SD cards and USB memory devices

This section describes how to use your sound system to access and playback your audio files via USB memory devices and Secure Digital (SD, SDHC) cards. The S300 can also record to SD, SDHC or USB media in MP3 format.

**Important:** *Your sound system is only designed to work with USB memory flash memory devices. It is not intended to be connected to computers, hard disk drives or any other type of USB device.*

The S300 has been tested with a range of USB memory devices of up to 64GB capacity, SD cards up to 2GB, and SDHC cards up to 32GB. However, there are many different card variants available and not all cards can be guaranteed to work in the S300. SDXC cards are not supported. Memory must be formatted using the FAT 16 or FAT 32 filing system in order to operate in the S300.

Audio formats supported for playback are MP3 and WMA. Playback does not support files encoded using WMA Lossless, WMA Voice, WMA 10 Professional, nor files of any format which have DRM protection.

The SD card slot is located on the front panel and the USB slot is located on the rear panel of your sound system.

### Inserting and removing memory devices

1. To insert an SD card into your sound system push the card label side upward and gold contacts first into the card slot on the front of your sound system until it clicks. To remove the card push the card in so that it clicks once more. It will then be pushed out slightly allowing removal.
2. USB memory devices plug into the rectangular slot on the rear of your sound system.
3. To select either SD card or USB mode press the **Media** button until the desired mode is shown on the display.

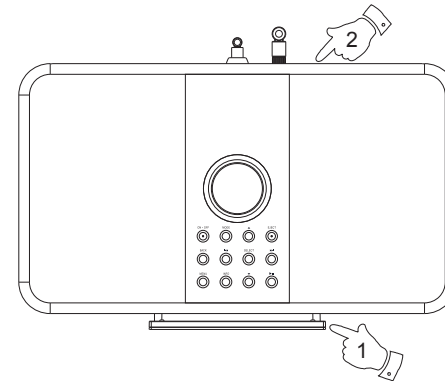

#### Cautions:

In order to minimise the risk of damage to your sound system, your SD card or your USB memory, please place the unit such that the device cannot easily be knocked while it is inserted in the socket.

Remove the USB memory or SD card before carrying the unit or if not using the USB or SD feature for a prolonged period.

Place the unit in Standby mode before removing your SD card or USB memory device.

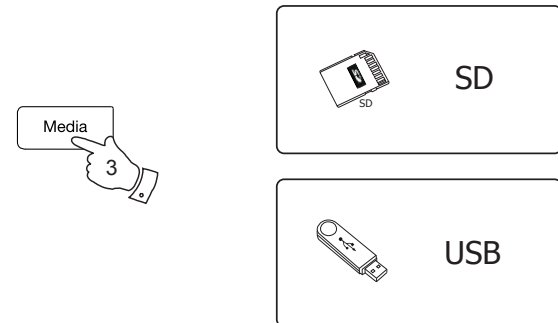

## Playing MP3/WMA files - SD/USB

1. Press the **Play / Pause** button to start playing from the SD card / USB memory device. The display will show the first folder and file numbers - "01" and "001".
2. To pause playing press the **Play / Pause** button. To resume playing press the **Play / Pause** button again.
3. To stop play, press the **Stop** button. The total number of files and folders on the media will be displayed.

If you put the unit into standby mode without pressing the Stop button, then the next time the unit is switched on it will return to the previously played file.

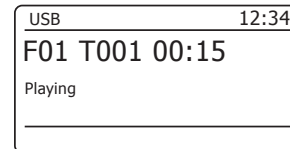
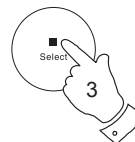
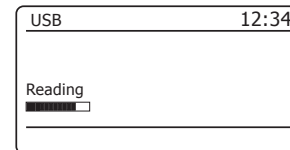

## Selecting a file

1. While the SD card / USB memory device is playing, press either the **Next** or **Previous** buttons to change to the desired file. The file number is updated in the display. If there is more than one folder, when all files in the current folder have been played the next folder will be played.
2. You can also skip files when the player is in stop mode. Skip to the desired file using the **Next** or **Previous** buttons and release the button when the desired file number is displayed.
3. Press the **Play / Pause** button to play the selected file.

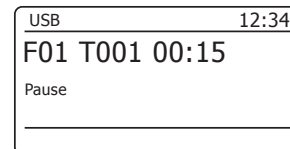
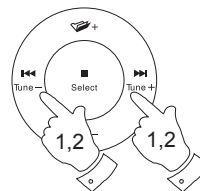

## Select a specific file

- For file numbers 1-9 simply press the corresponding digit button on the remote control. For file numbers ten and above press the required digits using the 10/0 button to enter the digit zero.
- If the file number entered exceeds the number of playable files on the SD card / USB memory device, then the last file will be played.

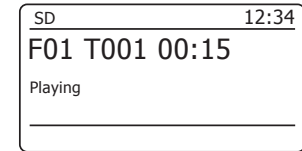
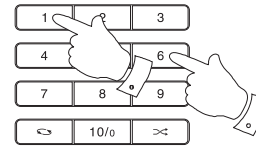

File numbers up to 999 may be entered. The numbers of files in folders are added together. So, for example, if the first two folders each contain 10 files, then entering 15 will play the fifth file in the second folder.

## Search function

- While the SD card / USB memory device is playing, press and hold the **Next** or **Previous** buttons. Release the button when the desired part of the current file is reached.

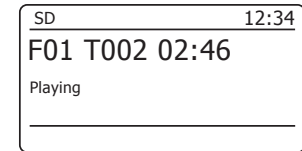
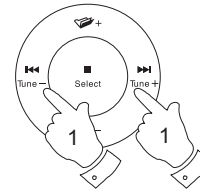

## To skip to another folder

- Whether the SD card / USB memory device is playing or stopped, press and release either the **Folder Up** or **Down** buttons. The first file of the next or previous folder on the memory will be played.

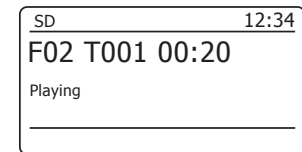
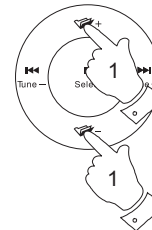

## Repeat, intro, shuffle and programmed play

The S300 allows you to use the same playback options for files as can be used for conventional audio CDs (see pages 74-77). In addition to Repeat Once and Repeat All options, there is also a Repeat Folder facility. Alternatively the repeat and shuffle options are available when using the menus.

## Recording to SD/USB

Your S300 sound system has been designed to allow you to make recordings to SD / SDHC cards or to USB connected memory devices. Recordings are made in MP3 format at 128k bits per second.

SD / SDHC or USB memory media must use the FAT16 or FAT32 file system in order to operate with the S300. Such media is usually supplied already formatted or can be formatted using a PC with a suitable card reader (for SD / SDHC cards) or USB connection (for USB memory).

It is possible to record onto media which already contains files written by the sound system or your computer. The recorded files will be added to those already present on the media.

**Note: The recording feature is not available when using Spotify Connect or when the sound system is acting as a client in a multi-room group, please see page 102.**

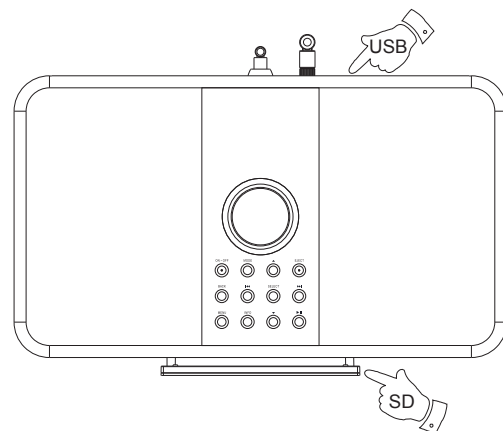

## Making a recording

1. Select the desired source for the recording (Internet Radio, DAB, FM, CD, etc.). Internet Radio is shown in the illustration. Set the volume to the required listening level (the volume of the recording will not be affected by this).
2. Insert the media on to which the recording is to be made.
3. Press the **Record** button. The display will show "Record initial...". Recording will then start with the recording source shown on the display.

If only one media type is present, then after a short while recording will start. If both SD and USB media are detected, then the sound system will default to the option previously set. The default media option is accessed through the 'System settings' menu then by selecting 'Rec default dest.'. Select 'SD card' or 'USB' memory as needed.

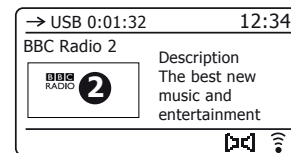
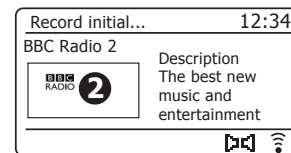
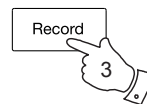



## Making a recording cont.

If recording from a CD, recording will be started from the beginning of the currently playing track. Each track on the CD will be recorded as a separate file on the media.

- In order to stop the recording press and release the **Record** button once more. Recording will stop and a file will have been written to the storage media.

Files that have been written to the media are held in a folder called "RECORD". Recordings are held in sub-folders according to the source used for the recording.

The illustration shows the folders as they may appear on a PC running Windows with files in the CD folder being shown to the right. Other folders on the memory device were copied there from the PC.

- AUXIN - for recordings from the Auxiliary input
- BT - for recordings from Bluetooth devices
- CD - for recordings from CD audio discs
- COPY - for recordings from SD / USB / CD (MP3/WMA)
- DAB, FM - for recordings from DAB and FM radio
- IR - for recordings from internet radio
- MP - for recordings from the music player

**Note:** The SD card / USB memory device should only be removed when recording is stopped. Removing media while recording is in progress may corrupt data on the card leading to the loss of files previously written.

The USB connection is intended to be used to allow the S300 to play MP3 and WMA files from solid-state flash memory devices. The USB connection is not intended to be connected to other USB devices such as computers or hard disk drives. If you wish to play files from another music player, then we recommend that this is connected to the Auxiliary input socket - see page 114.

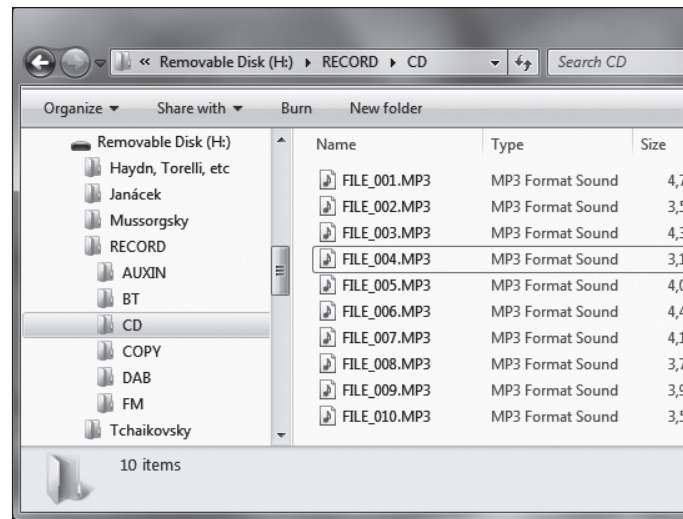
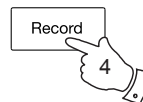

If you wish to make recordings from radio, we recommend recording from DAB radio if possible since it is generally less susceptible to interference than FM radio. If you need to record from FM radio, some interference may be picked up from the memory device unless you have a strong signal. The use of an external aerial for FM listening and recording can significantly improve the FM signal under these conditions. The section "Aerial removal" on page 115 of this booklet explains how to remove the telescopic aerial so that an external aerial can be connected via coaxial cable to the antenna connector.

## Recording MP3 / WMA files from CD / SD / USB

In addition to recording from conventional sources, the S300 sound system can also record from MP3 or WMA files that have previously been written to CD, SD or USB media. In this case the files are copied rather than re-encoded to MP3 in order to avoid a reduction in quality. You may copy files from CD or SD to USB and from CD or USB to SD.

1. Select the desired source for the recording (SD, USB or CD).
2. Press the **Play/Pause** button to start playing the source media (if it does not automatically start). Set the volume to the required listening level (the volume of the recording will not be affected by this).
3. Insert the media that the files will be recorded on to (SD or USB).
4. Press the **Record** button. The display will show "Record initial...".
5. If only one media type is present, the audio will stop while the source media is taken back to the beginning of the current file. Recording will then start.
6. If both SD and USB media are detected, then the sound system will default to the option previously set. The default media option is accessed through the 'System settings' menu then by selecting 'Rec default dest.'. Select 'SD card' or 'USB' memory as needed. The source media will be taken back to the beginning of the current file and recording will then start.
7. In order to stop the recording press the **Record** button once more. Recording and playback will stop and all files that have been played will have been copied to the storage media.

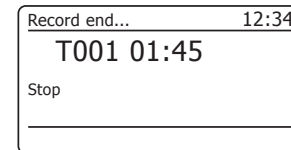
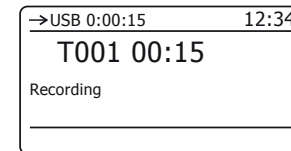
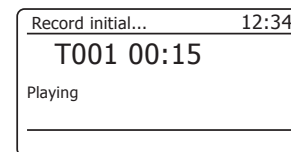
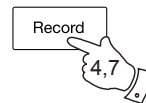
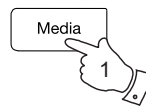

## Deleting files

After having recorded files to SD or USB media, you may later wish to delete them in order to reclaim the space used. The S300 can be used to delete individual files, or to delete all of the media files on the media.

### Deleting a single file

1. With the sound system in USB or SD mode, and with the media inserted and the file you wish to delete is currently playing, **press and hold** the **Menu** button.
2. Press the **Menu Up** or **Down** buttons until 'Delete this file' is highlighted on the display.
3. Press and release the **Select** button. The display will ask you if you wish to 'Delete this file?'
4. If you do not wish to delete the file, use the **Menu Up** or **Down** button to highlight 'NO' and press and release the **Select** button to confirm.

Alternatively, to delete the file use the **Menu Up** or **Down** button to highlight 'YES' and press and release the **Select** button to confirm deletion.

The file will be deleted and playback will resume from the beginning of the current folder. If there are no more files left on the media, then the display will show 'No Music File'.

**Note:** Once a file has been deleted, it is not possible to recover the file.

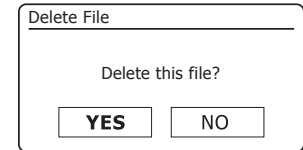
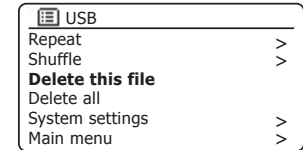
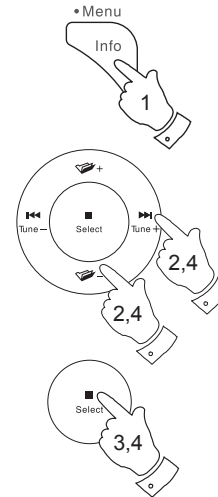

## Deleting files cont.

### Deleting all files

1. With the sound system in USB or SD mode, and with the media inserted **press and hold** the **Menu** button.
2. Press the **Menu Up** or **Down** buttons until 'Delete all' is highlighted on the display.
3. Press and release the **Select** button. The display will ask you if you wish to 'Delete all files?'
4. If you do not wish to delete all the files, use the **Menu Up** or **Down** button to highlight 'NO' and press and release the **Select** button to confirm.

Alternatively, to delete all the files on the media use the **Menu Up** or **Down** button to highlight 'YES' and press and release the **Select** button to confirm deletion.

All the files will be deleted. If there are no more files left on the media, then the display will show 'No Music File'.

The operation will generally only take a few seconds. When completed, the display will show 'No Music File'.

**Note:** Once the files have been deleted, it is not possible to recover the previous contents.

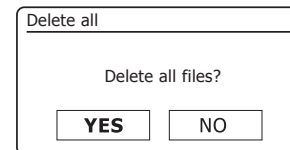
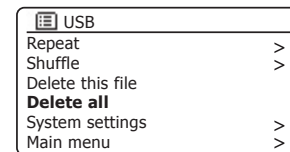
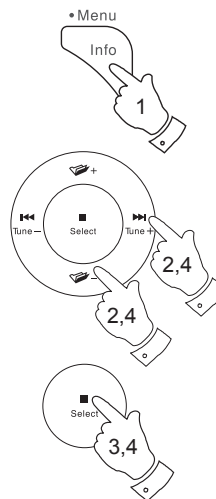

## Automatically updating the clock

Your sound system will normally update the clock automatically when connected to the internet. If you enter a time setting manually, the sound system will calculate a local time offset which is then stored in memory. Whenever it synchronises the clock using the internet, including after a power failure, your sound system will then set the clock automatically using this information.

You may wish to use the sound system away from the internet, in which case you may specify that the unit sets its clock from DAB or FM radio broadcasts. After a power failure the sound system will then set its clock the next time that you turn on the radio in DAB or FM mode.

Alternatively you may specify that the time is not automatically updated. In this case the clock must always be set manually after a power interruption.

1. With your sound system switched on, **press and hold** the **Menu** button to access the menu for the current mode.
2. Press the **Menu Up** or **Down** buttons until 'System settings' is highlighted on the display. Press and release the **Select** button to enter the System Settings menu.
3. Press the **Menu Up** or **Down** buttons until 'Time/Date' is highlighted on the display. Press and release the **Select** button to enter the time setup.
4. Press the **Menu Up** or **Down** buttons until 'Auto update' is highlighted on the display. Press and release the **Select** button to enter the Auto Update menu.
5. Press the **Menu Up** or **Down** buttons to choose an update option from 'Update from DAB', 'Update from FM', 'Update from Network' or 'No update' as required. Press and release the **Select** button to confirm your choice. The sound system will then exit to the previous menu display.

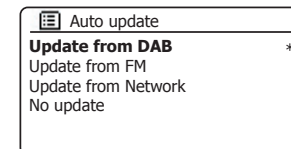
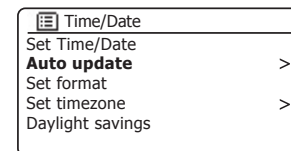
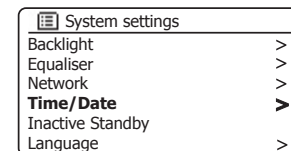
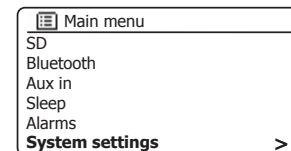
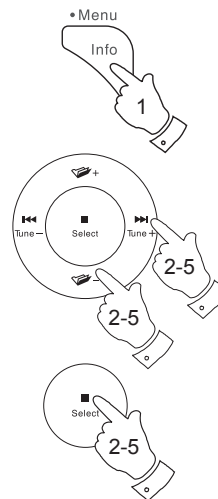

## Setting the clock format

The clock display used in Standby mode and on the playing mode screens can be set to 12 or 24 hour format. The selected format is then also used when setting the alarms.

1. With your sound system switched on, **press and hold** the **Menu** button to access the menu for the current mode.
2. Press the **Menu Up** or **Down** buttons until 'System settings' is highlighted on the display. Press and release the **Select** button to enter the System Settings menu.
3. Press the **Menu Up** or **Down** buttons until 'Time/Date' is highlighted on the display. Press and release the **Select** button to enter the time setup.
4. Press the **Menu Up** or **Down** buttons until 'Set format' is highlighted on the display. Press and release the **Select** button to enter the Clock Format menu.  
The current clock display format is marked with an asterisk.
5. Press the **Menu Up** or **Down** buttons to select either 12 or 24 hour format. Press and release the **Select** button to confirm your choice of clock format. The display will then revert to the previous menu.

If the 12 hour clock format is chosen, the sound system will then use the 12 hour clock for the setting of alarms, and will display a 12 hour clock with an AM or PM indicator when in standby mode.

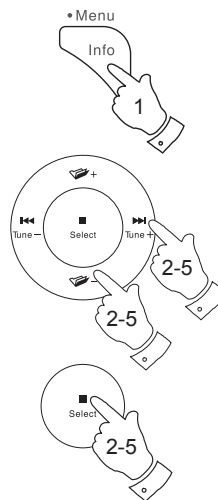
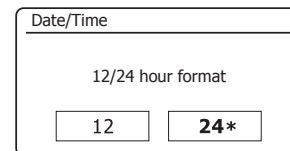
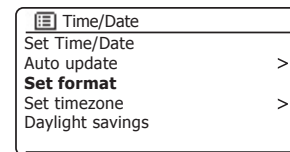
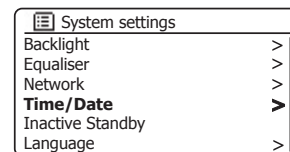
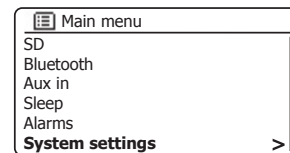

## Manually setting the clock

After a connection to the Internet has been established, your product will normally set its clock automatically to the local time zone that was specified during setup (see page 12). Should you need to set the time manually, change the time zone, or manually switch from winter to summer time (from GMT to BST in the UK, also commonly known outside the UK as daylight savings time), then please follow this procedure.

1. Press the **On/Standby** button to switch on your sound system.
2. **Press and hold** the **Clock set** button (on the remote control) and then skip to step 6 below. Alternatively **press and hold** the **Menu** button to access the menu for the current mode.
3. Press the **Menu Up** or **Down** buttons until 'System settings' is highlighted on the display. Press and release the **Select** button to enter the System Settings menu.
4. To change the time zone setting go to step 11. To change from winter to summer time go to step 13.  
To change the current time or date setting press the **Menu Up** or **Down** buttons until 'Time/Date' is highlighted on the display, then press and release the **Select** button to enter the time and date setting screen.
5. Press the **Menu Up** or **Down** buttons until 'Set Time/Date' is highlighted on the display. Press and release the **Select** button to enter the clock setup. The day digits will flash.
6. Press the **Menu Up** or **Down** buttons until the correct day is shown on the display. Press and release the **Select** button to enter the selection. The month digits will then flash.
7. Press the **Menu Up** or **Down** buttons to select the correct month. Press and release the **Select** button to enter the selection. The year digits will then flash.

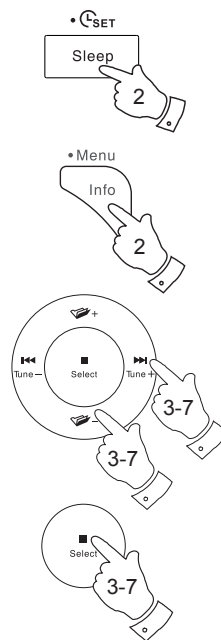

## Clock and Alarms

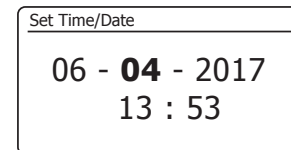
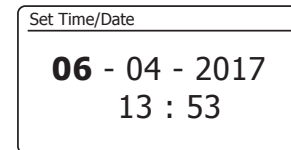
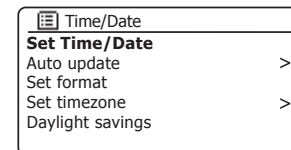
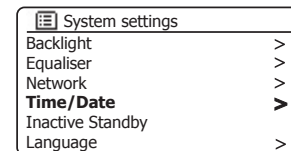
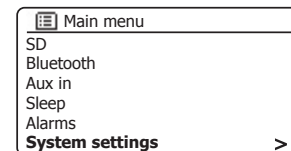

## Manually setting the clock - cont.

8. Press the **Menu Up** or **Down** buttons to select the correct year. Press and release the **Select** button to enter the selection. The hour digits will then flash.

9. Press the **Menu Up** or **Down** buttons to select the correct hour. Press and release the **Select** button to enter the selection. The minute digits will then flash.

10. Press the **Menu Up** or **Down** buttons to select the correct minutes. Press and release the **Select** button to enter the selection. The display will then return to the previous menu.

11. Press the **Menu Up** or **Down** buttons until 'Set timezone' is highlighted on the display then press and release the **Select** button.

12. Press the **Menu Up** or **Down** buttons to highlight the time zone which is applicable to your location, press and release the **Select** button to confirm the setting.

Press the **Back** button to exit or go to step 13 to set the summer / winter time option.

13. Press the **Menu Up** or **Down** buttons until 'Daylight savings' is highlighted on the display then press and release the **Select** button. The asterisk shows the current setting.

In the UK, ON is equivalent to British Summer Time, OFF is equivalent to Greenwich Mean Time.

14. Press the **Menu Up** or **Down** buttons to highlight 'ON' or 'OFF' as required then press and release the **Select** button to confirm the setting.

15. Press the **Back** button to exit.

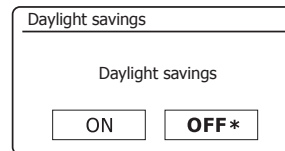
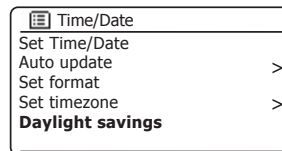
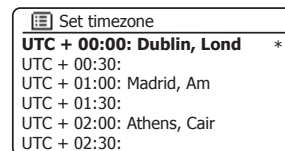
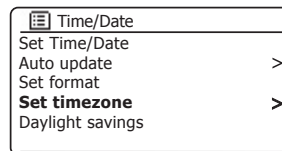
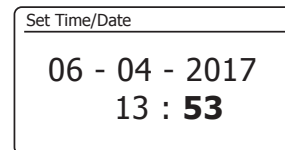
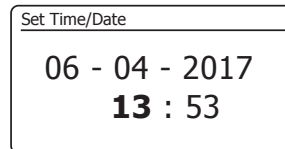
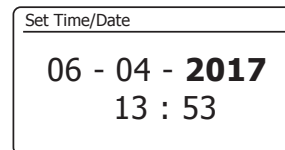
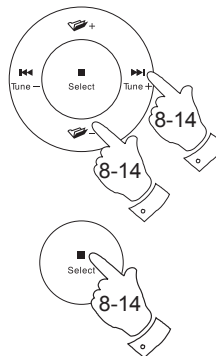



## Setting the alarm clock

Your sound system has two separate alarms which can be set to wake you to either the radio, CD, USB, SD or a buzzer alarm. In the event of a power interruption your sound system has built in memory that will retain your alarm settings. Ensure that the time is set correctly before setting the alarms.

Alarms may be set while the sound system is in standby mode or switched on.

If your sound system is being used as part of a multi-room system, please also see 'Alarm and Multi-room' page 108.

1. To change the states of the alarms *while the sound system is in Standby* press the **Alarm** button. The display will cycle through No Alarm, Alarm 1 enabled, Alarm 2 enabled or Alarms 1 and 2 enabled.
2. To change the alarm settings *while the sound system is in Standby*, **press and hold** the **Alarm** button. This will cause the Alarms menu to be displayed. Then skip to step 5 below.
3. To change the alarm settings *while the sound system is switched on*, either press and release the **Alarm** button and then skip to step 5 below, or alternatively **press and hold** the **Menu** button to access the menu for the current mode. Press the **Menu Up** or **Menu Down** buttons until 'Main menu' is highlighted on the display. Press and release the **Select** button to enter the Main menu.
4. Press the **Menu Up** or **Menu Down** buttons until 'Alarms' is highlighted on the display. Press and release the **Select** button to see the current alarm settings. If no change is required, press the **Back** button to exit.
5. Press the **Menu Up** or **Menu Down** buttons until the desired alarm (1 or 2) is highlighted on the display. Press and release the **Select** button to enter alarm setup.
6. Press the **Menu Up** or **Menu Down** buttons until 'Time' is highlighted on the display. Press and release the **Select** button to adjust the alarm time.
7. Press the **Menu Up** or **Menu Down** buttons to choose the alarm hour. Press and release the **Select** button to confirm the setting.

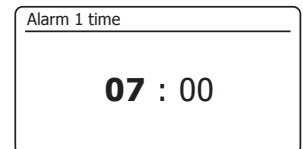
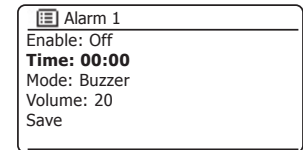
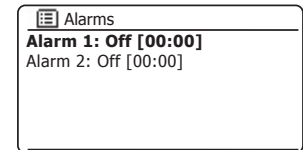
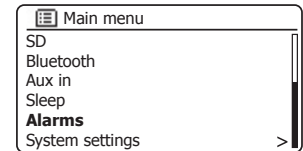
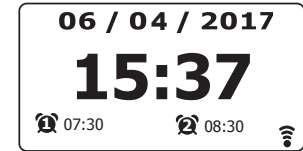
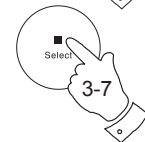
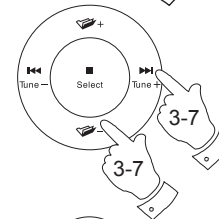
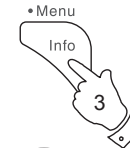
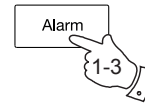

## Setting the alarm clock - cont.

8. Press the **Menu Up** or **Down** buttons to choose the alarm minute. Press and release the **Select** button to confirm the setting. The display will then return to the alarm setting menu.

If the sound system has been set to use a 12 hour clock format, there will also be an option here for setting AM or PM for the alarm time.

9. Press the **Menu Up** or **Down** buttons to highlight 'Enable' and press and release the **Select** button. The display will show the Frequency options for the alarm. The alarm frequency options are as follows:

'Off' - the alarm will be disabled

'Daily' - the alarm will sound everyday

'Once' - the alarm will sound once

'Weekends' - the alarm will sound only at weekends

'Weekdays' - the alarm will sound on weekdays only

Press the **Menu Up** or **Down** buttons to choose the required alarm frequency option. Choosing Off will disable the alarm. Press and release the **Select** button to confirm the selection.

If you choose to set the alarm to Once you will also need to set the date using the **Menu Up** or **Down** and **Select** buttons.

10. The alarm can be set to buzzer, Internet radio, DAB or FM radio, CD, USB and SD card. For whichever radio mode is selected, the radio alarm may be set to any of the stations which have been stored as presets or to the station most recently listened to.

Press the **Menu Up** or **Down** buttons to highlight the current 'Mode' option for the alarm, then press and release the **Select** button if you wish to change it.

Press the **Menu Up** or **Down** buttons to highlight either 'Buzzer' or the required mode. Press and release the **Select** button to confirm the selection.

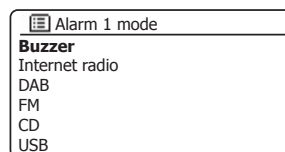
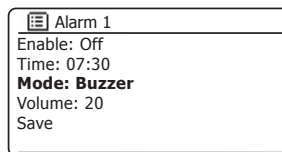
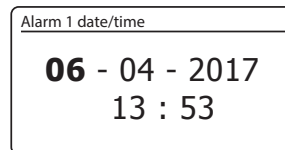
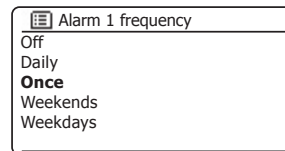
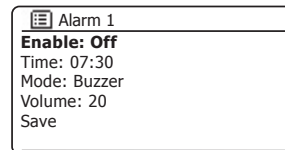
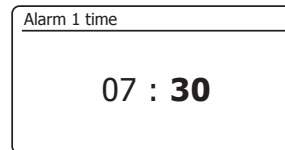
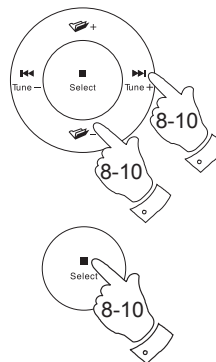

## Setting the alarm clock - cont.

11. If setting the alarm to a radio option, press the **Menu Up** or **Down** buttons to highlight the '*Preset:*' option then press and release the **Select** button if you wish to change it.

Choose from either the radio station '*Last listened*' to, or from the presets 1 - 10. Scroll to the chosen option and press the control to confirm the selection.  
**Note:** The alarm may only use a preset which has already been stored.

12. Press the **Menu Up** or **Down** buttons until the '*Volume:*' option is highlighted on the display and press and release the **Select** button if you wish to change it. The sound system uses the saved volume setting for each alarm when it sounds.

Press the **Menu Up** or **Down** buttons to set the required volume and then press and release the **Select** button to confirm the setting.

13. In order to store the alarm settings press the **Menu Up** or **Down** buttons until '*Save*' is highlighted. Press and release the **Select** button to store the alarm settings. Your sound system will show '*Alarm saved*' and will then go back to the list of alarms with the new alarm setting shown in the display.

If you decide not to save the settings, press the **Back** button. The display will show '*Save changes*' with a '*YES*' or '*NO*' option. Press and release the **Menu Up** or **Down** buttons to choose '*NO*' and then press and release the **Select** button. '*Alarm not saved*' will show on the display.

Active alarms are shown using small alarm indicators at the bottom of the playing displays and on the clock display when in Standby.

**Note:** If you make a mistake at any point while setting the alarms, use the **Back** button to go back to the previous screen.

## When the alarm sounds

The buzzer or radio alarm will sound at the selected times for up to 60 minutes unless cancelled. The volume used for the alarm will be as specified during the alarm setting procedure. If the radio cannot connect to the specified radio station, the buzzer alarm will be used instead.

If setting the alarm to CD, SD or USB ensure the media is inserted.

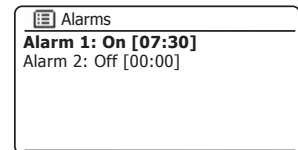
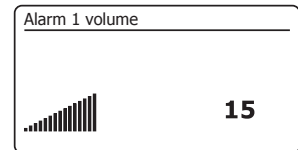
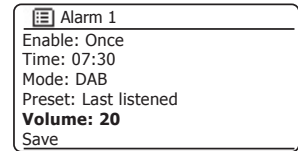
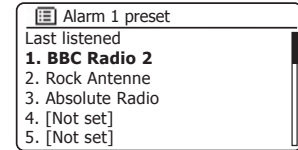
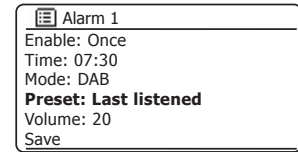
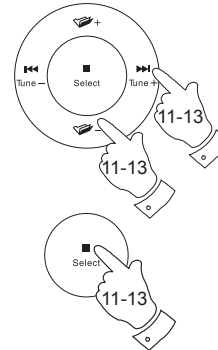

## When the alarm sounds cont.

1. During an alarm, the alarm icon will flash at the bottom of the playing mode displays. The sound system will automatically revert to standby mode after 60 minutes.
2. To cancel an alarm, press the **On/Standby** button to return to Standby mode.

**Note:** If the radio is switched on because of an alarm you can control basic functions such as volume. You cannot perform operations which involve the Select button since this also acts as the Snooze button (see below).

## Snooze timer

1. The buzzer or radio alarm can be silenced for 5 minutes by pressing the **Select/Snooze** button. Should you wish for a longer snooze duration this can be extended. Pressing the **Select** button again while the sound system is snoozed will set the available snooze time to 5, 10, 15 or 30 minutes.
2. While the snooze timer is active the remaining snooze time is shown next to the flashing alarm icon on the clock display.
3. In order to cancel the Snooze timer while the alarm is suspended, press the **On/Standby** button. The display will briefly show an 'Alarm Off' message.

## Disabling alarms

1. To disable an alarm while the unit is in standby mode press and release the **Alarm** button to cycle through the alarm on-off options (see page 94, step 1).
2. To disable an alarm while the unit is playing enter the Alarms menu (see page 94, steps 3 and 4) and press the **Menu Up** or **Down** buttons until the desired alarm is highlighted on the display. Press the **Select** button.
3. Press the **Menu Up** or **Down** buttons until the 'Enable:' option is highlighted on the display. Press and release the **Select** button.
4. Press the **Menu Up** or **Down** buttons to highlight 'Off' and press and release the **Select** button.
5. Press the **Menu Up** or **Down** buttons until the 'Save' option is highlighted on the display then press and release the **Select** button to save the new setting. The chosen alarm will now be disabled.

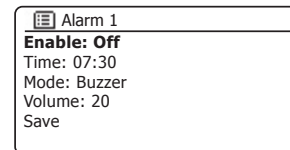
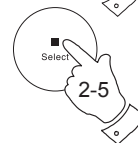
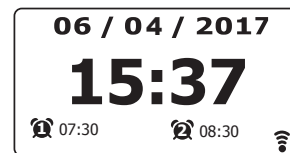
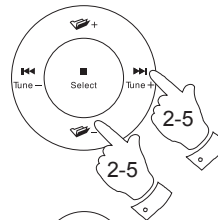
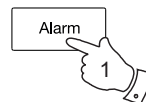
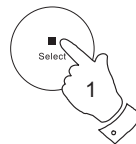
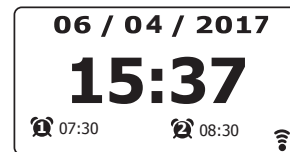

## Sleep timer

Your sound system can be set to turn off after a preset time has elapsed. The sleep timer setting can be adjusted between 15 and 90 minutes in 15 minute increments.

1. With your sound system switched on, press and release the **Sleep** button (on the remote control) or press and hold the **On/Standby** button to access the sleep timer.
2. Press and release the **Sleep** button on the remote control or press the **Menu Up** or **Down** buttons until the required sleep time setting is selected. The sleep timer can be set to between 15 and 90 minutes, or to Off. Press and release the **Select** button to confirm the setting.
3. The sleep timer will be set to the chosen duration. An active sleep timer is shown using a small timer indicator at the bottom of the playing displays. This indicator also shows the sleep time remaining before the radio switches itself into Standby mode.
4. Alternatively you can set the sleep time using the menu system. Access the menu for the current mode by **pressing and holding** the **Menu** button. Press the **Menu Up** or **Down** buttons until 'Main menu' is highlighted on the display. Press and release the **Select** button to enter the Main menu.
5. Press the **Menu Up** or **Down** buttons until 'Sleep' is highlighted on the display then press and release the **Select** button.
6. Press the **Menu Up** or **Down** buttons until the required sleep time setting is selected. Press and release the **Select** button to confirm the setting.
7. To cancel the sleep time before the preset time has elapsed and to turn off the sound system, press the **On/Standby** button to turn the unit off manually. To cancel the sleep timer and leave the sound system playing, go back into the sleep timer settings (steps 1 to 2 above) and select the Off option in step 2.

## Clock and Alarms

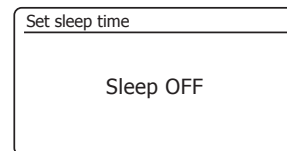
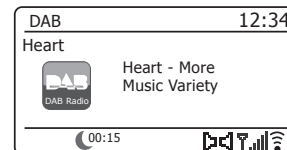
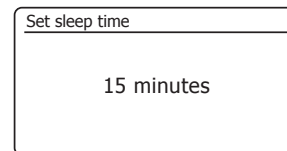
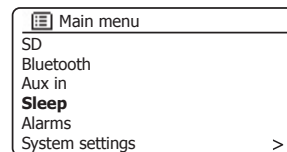
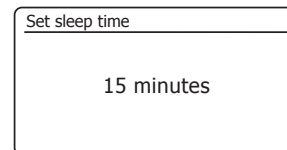
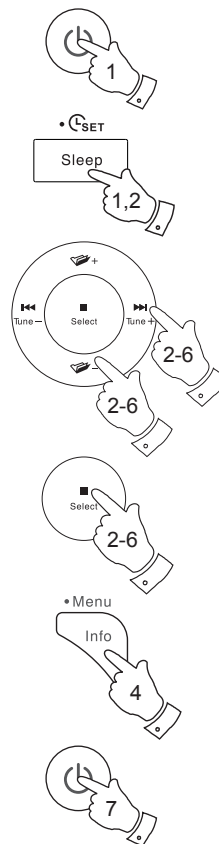

## Multi-room - the basics

Your S300 sound system may be used with other products as part of a multi-room system.

Products may be combined into a synchronised group allowing several units to play the same content around your home.

Multiple groups may be configured for different areas of the home or for different users.

Different products may use the same or different operating modes, but audio will not be synchronised between groups, only between products in the same group.

You may control a single product, a group of products, or even multiple groups using the UNDOK app or your sound system's controls.

Each group that you configure may contain up to five compatible products. Typically as many as 16 products may operate together on a single network. The maximum number of products that will work together reliably is dependent upon the reliability and capability of the network.

Compatible products from Roberts also allow content from other sources to be shared with all of the products in a group. These include CD, DAB and FM radio.

The UNDOK app allows you to:

- Create a group
- Rename a group
- Edit a group - add or remove one or more products
- Delete a group
- Control a group - choose operating mode and browse for content
- Adjust volume for an entire group or for individual products within a group
- Control products which have not been assigned to any group



Control via the UNDOK app

## Creating and editing a multi-room group with UNDOK

You can use the UNDOK app to combine your S300 sound system into a group with the other multi-room products.

**Note:** You may add up to five connected audio products into any one group.

1. Access your list of connected audio products within UNDOK.
2. A list of audio products connected to your network will be shown.
3. Select the edit group icon.
4. UNDOK will show the group setup screen and a list of the products available for grouping.
5. Select the audio products that you wish to add into your group (a maximum of four additional products). You may add or remove products as needed.
6. You may rename your group, for example *'Family Room'* or *'Down Stairs'* etc.
7. Confirm your selection.
8. You may choose to delete a group. The products that were previously in the group will then be listed as individual products.

## Multi-room & UNDOK

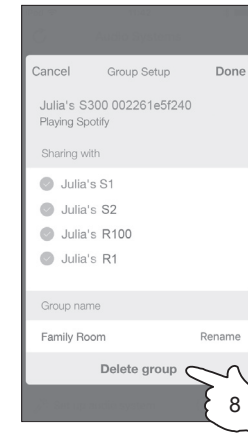
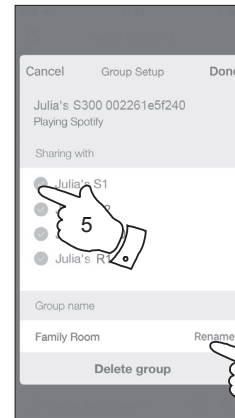
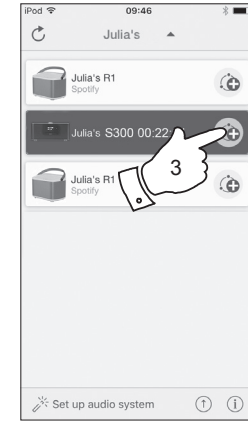
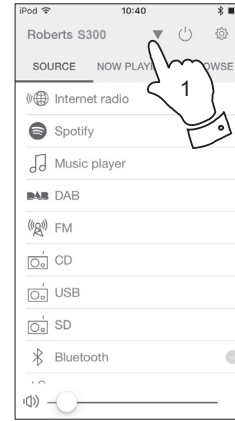

## Playing audio to a group

The process of choosing the audio source and content for a group of products is almost the same as for a single product.

1. Select the desired group (or individual product if not in a group).
2. Select the desired source. If more than one product offers the same source type, e.g. Bluetooth then each will be shown in the source menu.
3. Select 'Now Playing' or 'Browse' as needed to access content for the selected source.

## Volume control using UNDOK

UNDOK allows you to control the volume of a group of products and the volume of individual products within the group.

1. Use the multiple products icon to access the individual volume controls.
2. You may also mute either the group, or products within the group using the speaker icon.
3. The equaliser for products in a group can also be accessed from the group's volume control.

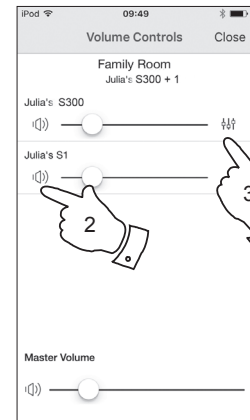
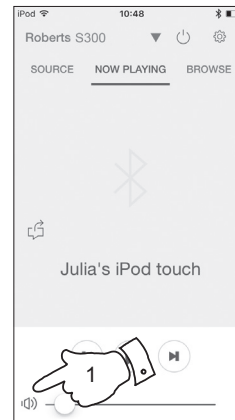
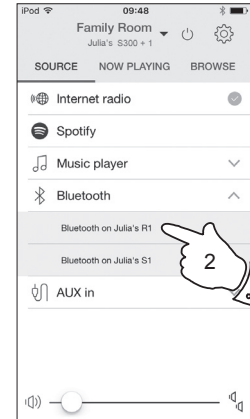
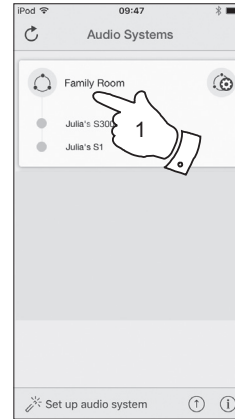



## Display and Controls in a multi-room configuration

1. When your sound system is used in a multi-room group and it is acting as the source, providing content to other products in the group, it is said to be acting as the group Master (or Server – please also see next page).

In this situation, the sound system's display will show the current operating mode and related information, just as if the sound system was operating alone and not as part of a multi-room group.

2. The buttons of the product will operate in all modes exactly as they do when the product is used on its own. The On / Standby button will control the On / Standby state of all products within the same group.
3. When your sound system is used in a multi-room group and it is receiving content from one of the other products in the group, it is said to be acting as a Client (please also see next page).

In this situation, the sound system's display will show that the sound system is active but is playing as part of the group. It will not be able to display additional information about the content being played in this mode.

4. While playing as a group client, the volume control buttons on the sound system will operate normally but will not affect others in the group.

Some of the media controls (Play / Pause / Previous track / Next track) will be available in some modes (Music player, for example) and will affect playing for all products within the group.

The On / Standby button may be used to put all of the devices in the group into Standby, or to switch them back on, as needed.

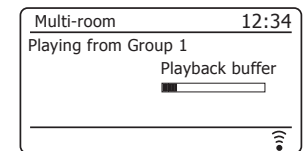
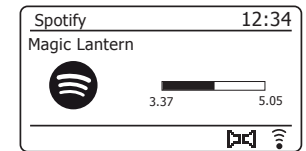
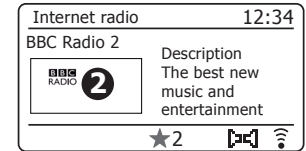

## Using your sound system's controls to configure multi-room

In addition to using the UNDOK app you may also use your sound system's controls to configure it as part of a group of multi-room products.

### View the sound system's multi-room details

To view the multi-room details for your S300 follow the below procedure.

1. Access the menu for the current mode, **press and hold** the **Menu** button.
2. Press the **Menu Up** or **Down** buttons until 'System settings' is highlighted on the display.
3. Press and release the **Select** button to enter the settings menu.
4. Press the **Menu Up** or **Down** buttons until 'Multi-room' is highlighted on the display. Press and release the **Select** button.
5. Press the **Menu Up** or **Down** buttons until 'View details' is highlighted on the display. Press and release the **Select** button. Your sound system's multi-room details will be shown on the display.
  - Ungrouped - The product is not part of a group.
  - Server - The product sends audio content to other group members.
  - Client - The product receives audio from another product in the group.
6. Press the **Back** button to exit the menu.

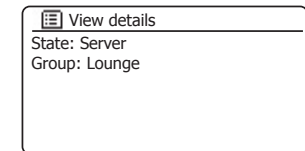
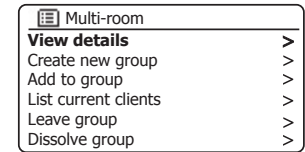
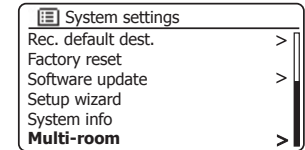
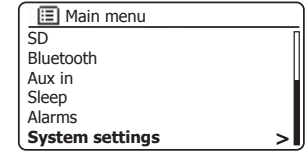
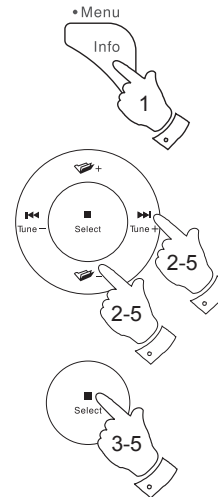

## Create a new multi-room group

You can create a new multi-room group using your sound system.

1. Access the menu for the current mode, **press and hold the *Menu*** button.
2. Press the ***Menu Up*** or ***Down*** buttons until '*System settings*' is highlighted on the display. Press and release the ***Select*** button to enter the settings menu.
3. Press the ***Menu Up*** or ***Down*** buttons until '*Multi-room*' is highlighted on the display. Press and release the ***Select*** button.
4. Press the ***Menu Up*** or ***Down*** buttons until '*Create new group*' is highlighted on the display. Press and release the ***Select*** button.
5. To enter the group name, characters are selected and entered using the ***Menu Up*** or ***Down***, ***Left*** or ***Right*** and ***Select*** buttons. The highlight scrolls through the available characters as well as the three controls on the right. The character currently highlighted will be entered when you press the ***Select*** button. Select the '[OK]' symbol when you have entered the text. You can quickly access the three symbols on the right by pressing the ***Info*** button and then use the ***Menu Up*** or ***Down*** and ***Select*** buttons as needed. The next screen will prompt you to add other connected multi-room products to the current group.
6. If you wish to add a product from the list to the new group, highlight the product using the ***Menu Up*** or ***Down*** buttons and press the ***Select*** button to confirm. The screen will show '*Added*'. Products already added to the group are marked with an asterisk.
7. If you do not wish to add another product to the current group press the ***Back*** button to exit.

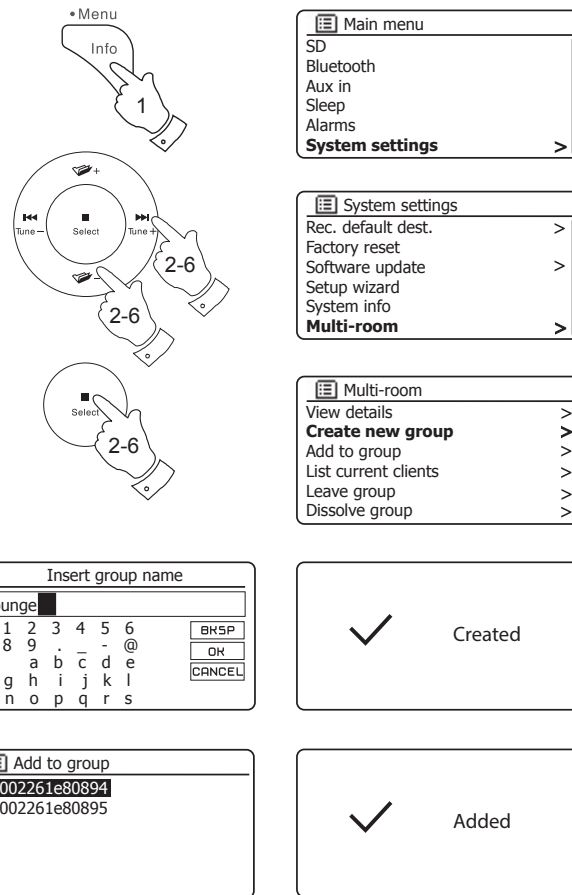

## Add products to the current group

You can add other connected multi-room products to the current group using your S300 sound system.

1. Access the menu for the current mode, **press and hold** the **Menu** button.
2. Press the **Menu Up** or **Down** buttons until 'System settings' is highlighted on the display.
3. Press and release the **Select** button to enter the settings menu.
4. Press the **Menu Up** or **Down** buttons until 'Multi-room' is highlighted on the display. Press and release the **Select** button.
5. Press the **Menu Up** or **Down** buttons until 'Add to group' is highlighted on the display. Press and release the **Select** button.
6. If you wish to add a product from the list to the current group, highlight the product using the **Menu Up** or **Down** buttons and press the **Select** button to confirm. The screen will show 'Added'. Products already added to the group are marked with an asterisk. If the adding process displays 'Failed' it is usually because the S300 is not yet controlling a group (see Creating new multi-room group page 104).
7. If you do not wish to add another product to the current group press the **Back** button to exit.

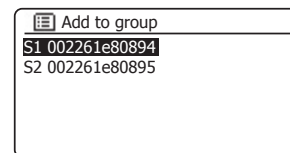
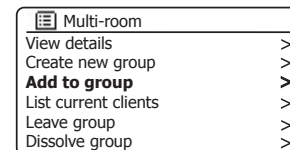
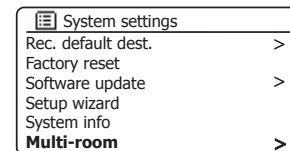
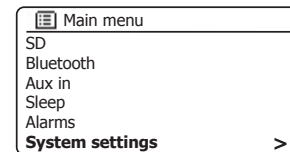
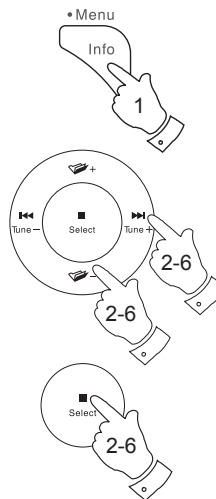

## Remove products from a current group

You may remove audio products from the current group using your sound system.

1. Access the menu for the current mode, **press and hold the *Menu*** button.
2. Press the ***Menu Up*** or ***Down*** buttons until '*System settings*' is highlighted on the display.
3. Press and release the ***Select*** button to enter the settings menu.
4. Press the ***Menu Up*** or ***Down*** buttons until '*Multi-room*' is highlighted on the display. Press and release the ***Select*** button.
5. Press the ***Menu Up*** or ***Down*** buttons until '*List current clients*' is highlighted on the display. Press and release the ***Select*** button. A list of current connected audio products will show on the display.
6. If you wish to remove a product from the current group, highlight the product using the ***Menu Up*** or ***Down*** buttons and press the ***Select*** button to confirm. The screen will show '*Removed*'.
7. If you do not wish to remove the product from the current group press the ***Back*** button to exit.

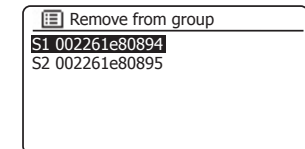
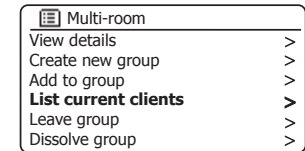
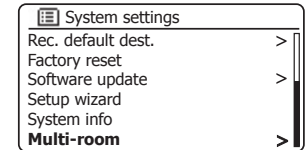
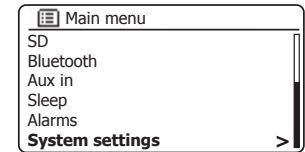
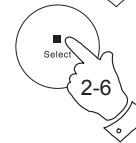
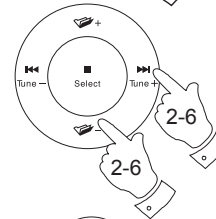
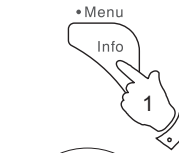

## Leave a group

Your S300 sound system can be removed from a current group.

1. Access the menu for the current mode, **press and hold** the **Menu** button.
2. Press the **Menu Up** or **Down** buttons until 'System settings' is highlighted on the display.
3. Press and release the **Select** button to enter the settings menu.
4. Press the **Menu Up** or **Down** buttons until 'Multi-room' is highlighted on the display. Press and release the **Select** button.
5. Press the **Menu Up** or **Down** buttons until 'Leave group' is highlighted on the display. Press and release the **Select** button.
6. Your S300 will be removed from the current group.

If your S300 was previously sending audio to other products in the group that will cease. The other products will remain in the group and must then be 'operated' separately.

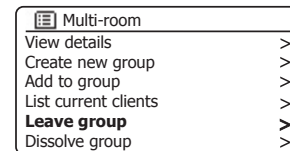
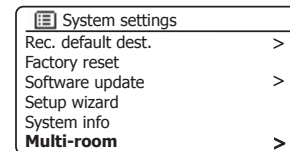
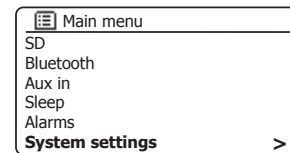
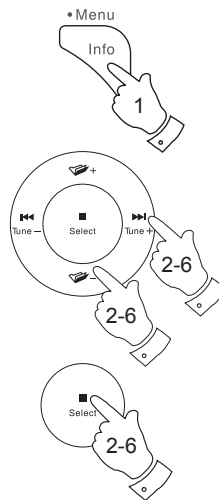

## Dissolve a group

You can dissolve a current group.

1. Access the menu for the current mode, **press and hold the *Menu*** button.
2. Press the ***Menu Up*** or ***Down*** buttons until '*System settings*' is highlighted on the display.
3. Press and release the ***Select*** button to enter the settings menu.
4. Press the ***Menu Up*** or ***Down*** buttons until '*Multi-room*' is highlighted on the display. Press and release the ***Select*** button.
5. Press the ***Menu Up*** or ***Down*** buttons until '*Dissolve group*' is highlighted on the display. Press and release the ***Select*** button.
6. The current group will be dissolved.  
Each of the products that were in the group can now be operated individually.

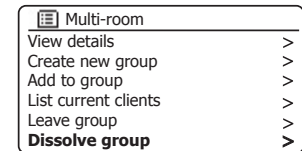
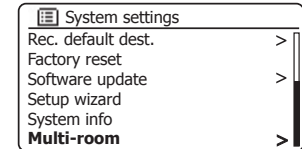
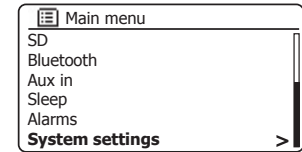
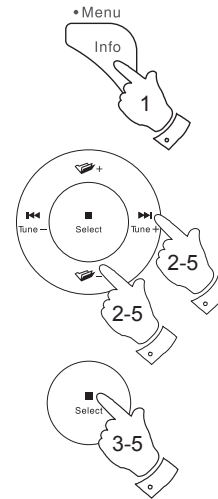

## Alarms and Multi-room

If your sound system is configured as part of a multi-room group, then the sound system will remove itself from that group when the sound system switches itself on as a result of an alarm having been set. This is so that an alarm sounding on one radio will not cause all of the other products in the group to be activated at the same time.

If you wish to use your sound system as part of a multi-room group after using the alarm function, you will need to add the sound system back into the group manually. This is most easily performed using the UNDOK app as described on page 100.

# UNDOK Settings

## Equaliser function

The sound on your sound system can be adjusted to suit your personal taste for the material that you are listening to. The S300 has a range of equaliser modes. Alternatively, you may set the bass, mid-range and treble levels to your own preferences.

1. Select the 'Settings' screen and then select 'Equaliser' in UNDOK.
2. Choose the desired equaliser setting or select the 'My EQ' option to adjust the bass, mid-range and treble setting.

## Sleep timer

Your sound system can be set to turn off after a preset time has elapsed. The sleep setting can be adjusted as follows.

1. Set the sleep timer using the UNDOK app.
2. Your sound system will switch off after the preset sleep timer has elapsed.

## Friendly name

Your sound system is identified within the UNDOK app using its Friendly Name. By default, your sound system's name will be shown as "Roberts S300" followed by a 12 digit alphanumeric code which is the network MAC address that is unique to your sound system. Use the sound system's settings in UNDOK to change its friendly name.

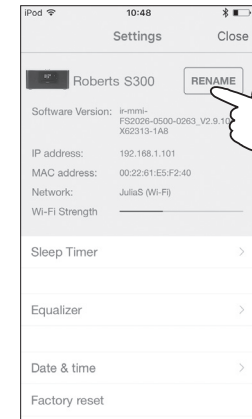
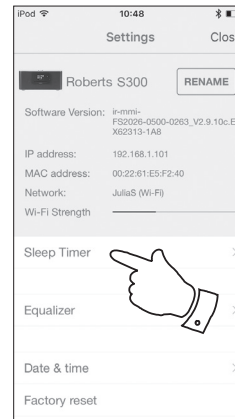
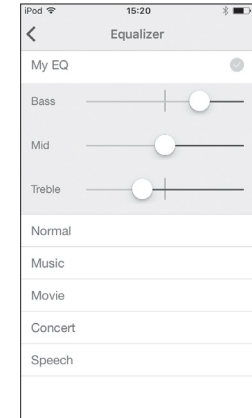
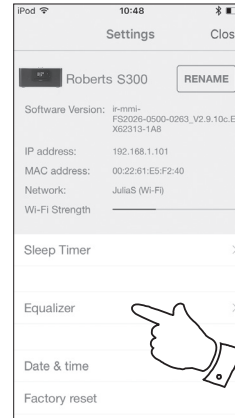



## Equaliser function

The sound on your sound system can be adjusted to suit your personal taste for the material that you are listening to. The S300 has a range of equaliser options. Alternatively you may set the bass, mid-range and treble levels to your own preferences which can be accessed from the *My EQ* menu item.

1. Press the **On/Standby** button to switch on your sound system.
2. Press the **EQ** button (on the remote control) to access the EQ menu and then skip to step 5 below. Alternatively to access the EQ menu, **press and hold** the **Menu** button.
3. Press the **Menu Up** or **Down** buttons until 'System settings' is highlighted on the display. Press and release the **Select** button to enter the System Settings menu.
4. Press the **Menu Up** or **Down** buttons until 'Equaliser' is highlighted on the display. Press and release the **Select** button.
5. Press the **Menu Up** or **Down** buttons to cycle through and highlight the various modes. Press and release the **Select** button to confirm your selection.

- a - 'Normal'
- b - 'Music'
- c - 'Movie'
- d - 'Concert'
- e - 'Speech'
- f - 'My EQ'

The currently selected mode is marked with an asterisk.

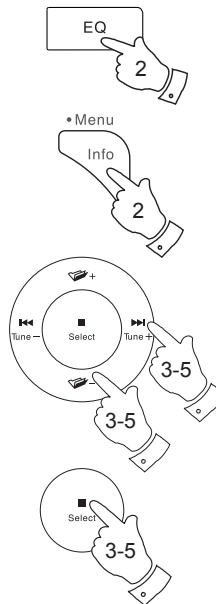

## Display and Audio

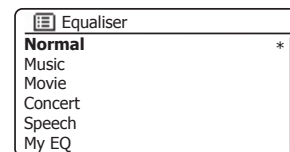
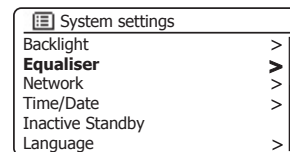
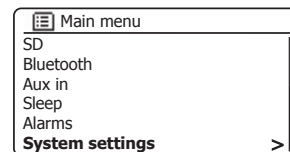
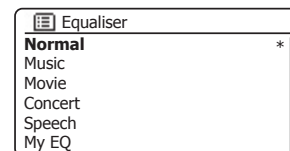

## Setting up your My EQ profile

If you find the preset equaliser functions not to your liking, you may set up a custom bass, mid-range and treble setting as follows:

1. Follow steps 1-4 on the preceding page in order to enter the Equaliser menu.
2. Press the **Menu Up** or **Down** buttons until 'My EQ profile setup' is highlighted on the display. Press and release the **Select** button to enter the adjustment mode.
3. To adjust the bass level press the **Menu Up** or **Down** buttons until 'Bass' is highlighted on the display. Press and release the **Select** button to enter the adjustment mode and press the **Menu Up** or **Down** buttons until the desired level (between -6 and +6) is displayed. The sound will change as you adjust the levels. Press and release the **Select** button when you are happy with the bass setting.
4. To adjust the mid-range or treble level press the **Menu Up** or **Down** buttons until 'Mid' or 'Treble' is highlighted on the display. Press and release the **Select** button to enter adjustment mode and press the **Menu Up** or **Down** buttons until the desired level (between -6 and +6) is displayed. The sound will change as you adjust the level. Press and release the **Select** button when you are happy with the mid-range or treble setting.
5. Press the **Back** button and the display will prompt you to save the changes. If you wish to save the changes press the **Left** or **Right** buttons to highlight 'YES'. If you do not wish to save the changes highlight 'NO'. Press and release the **Select** button to enter the selection.
6. To use the 'My EQ' profile press the **Menu Up** or **Down** buttons until 'My EQ' is highlighted, and then press and release the **Select** button to make the selection.

To quickly cancel the effect of the 'My EQ' profile press the **Menu Up** or **Down** buttons until 'Normal' is highlighted on the display and press and release the **Select** button. The bass, mid-range and treble settings will be remembered for the next time that you wish to use the 'My EQ' setting.

**Note:** When listening on headphones only the Bass and Treble settings are used. The Mid setting will have no effect.

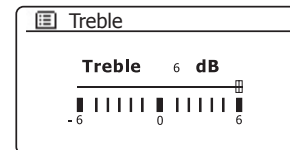
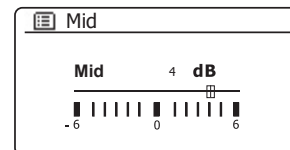
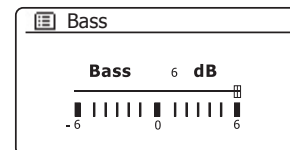
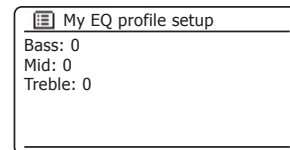
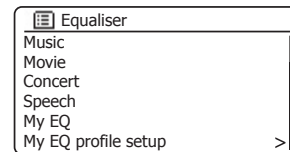
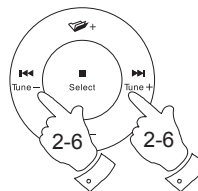

## Subwoofer control

In addition to the Equaliser functions described on pages 110 and 111, the sound system has an additional control for the subwoofer function. This controls the level of deep bass from the sound system's loudspeakers.

If your sound system is located in the corner of a room (especially on the diagonal) then you may need to reduce the subwoofer volume setting on the sound system. This is because the reflections from the walls around the corner will tend to enhance the bass response of the system. Conversely, in a large open area, you may wish to increase the subwoofer volume setting on the sound system.

1. The subwoofer volume control on the sound system remote control adjusts levels of the internal subwoofer function.
2. Alternatively, the subwoofer level setting in the system settings menu can be used to adjust the subwoofer level.

**Note:** When listening on headphones the subwoofer control has no effect.

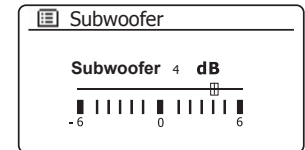
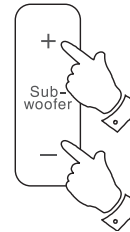

## Mute function

Pressing the Mute button will mute the output from the loudspeakers.

1. Press the **Mute** button (on the remote control) to mute the sound output.
2. Press the **Mute** button again or one of the volume buttons to un-mute the sound output.



## Brightness control

The brightness of the display can be adjusted for when the sound system is in standby and for when it is in use. If you use the unit in the bedroom, you may prefer a lower standby brightness level than the standard setting. There are a range of Standby brightness levels and a range for when the sound system is in use. To change the current brightness setting, please follow these steps.

1. Press and release the **Dimmer** button on the remote control to select the desired brightness level.
2. Alternatively, press the **On/Standby** button to switch on your sound system. To access the menu for the current mode **press and hold** the **Menu** button.
3. Press the **Menu Up** or **Down** buttons until 'System settings' is highlighted on the display. Press and release the **Select** button to enter the System Settings menu.

Press the **Menu Up** or **Down** buttons until 'Backlight' is highlighted on the display. Press and release the **Select** button.

4. To adjust the display brightness when the sound system is switched on press the **Menu Up** or **Down** buttons until 'Normal' is highlighted on the display.

To adjust the display brightness when the sound system is in standby press the **Menu Up** or **Down** buttons until 'Standby' is highlighted.

Press and release the **Select** button to enter the selected brightness adjustment mode. The current setting will be marked with an asterisk.

5. Press the **Menu Up** or **Down** buttons to choose the desired brightness level. Press and release the **Select** button to set the level. Press the **Menu** button to exit.

When the sound system is in Standby mode, pressing a button will cause the sound system to switch to the normal brightness level for a few seconds. This is so that even if the standby brightness level is set low, it is still possible to see the time when needed.

The settings in Standby mode are lower than their equivalents when the sound system is in use.

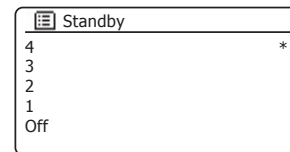
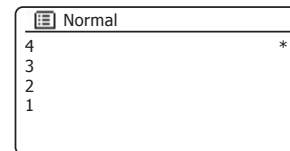
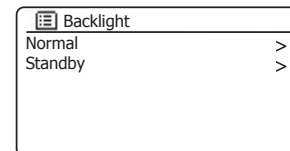
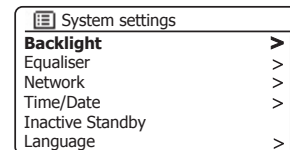
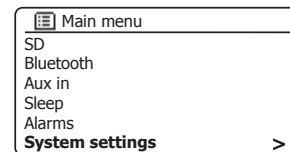
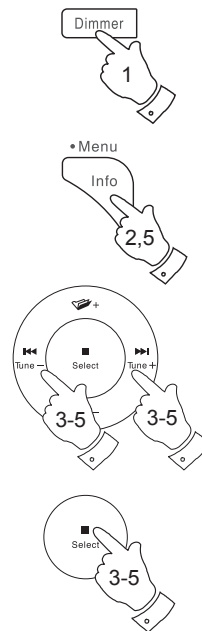

## Auxiliary input socket

A 3.5mm **Auxiliary Input** socket located on the rear of your sound system is provided for connecting the audio signal from an external audio source such as an MP3 or CD player.

1. Connect a stereo lead from the headphone output of your MP3 or CD player to the Aux In socket located at the rear of the sound system. Typically this lead will have a 3.5mm stereo plug at both ends.
2. Switch on your sound system.
3. Press the **Radio** button until *AUX in* mode is shown on the display.
4. Press 'play' on the connected audio device. If you are using its headphone output for the connection, set its volume control to a level of somewhere between two-thirds and maximum (the objective is to get a strong audio signal but without too much distortion).
5. After use, disconnect your player in order to listen to your sound system conventionally.

## Headphone socket

A 3.5mm **Headphone Socket** is provided at the rear of your sound system. The sound system controls the volume of the headphones independently of the loudspeaker volume. Inserting a plug automatically mutes the loudspeaker and the volume setting will change to the level last used for the headphones. When the headphones are unplugged the previous volume setting for the loudspeakers is applied.

Please be aware that the sensitivity of headphones can vary widely. We therefore recommend setting volume to a low level before wearing headphones.

**IMPORTANT:** Excessive sound pressure from earphones and headphones can cause hearing loss.



To prevent possible hearing damage, do not listen at high volume levels for long periods.

## Line out socket (3.5mm Jack)

A 3.5mm **Line Out** socket located on the rear of your sound system is provided for connecting the audio signal to an external amplifier. Inserting an audio cable into this socket will not mute the internal loudspeaker. Set the volume control on the sound system to minimum if desired.

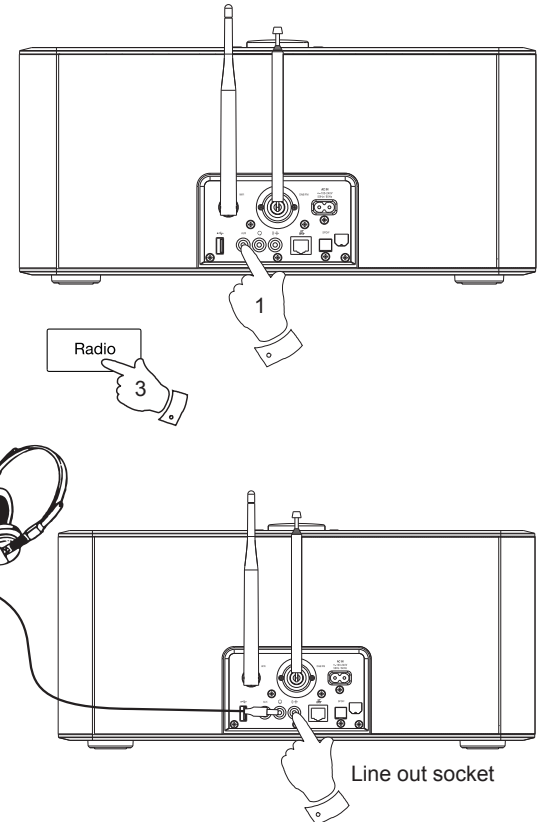

## Inactive Standby timer

The Inactive Standby timer allows your sound system to save power by automatically going to Standby if no controls are used for a period of time. By default this period is set to 8 hours but you may change it if you wish.

1. With your sound system switched on, **press and hold** the **Menu** button to access the menu for the current mode.
2. Press the **Menu Up** or **Down** buttons until 'System settings' is highlighted and press and release the **Select** button.
3. Press the **Menu Up** or **Down** buttons until 'Inactive Standby' is highlighted and press and release the **Select** button.
4. Choose from 2, 4, 6, 8 hours or Off. Your sound system will go into Standby after the selected time has expired. Setting Inactive Standby to Off will disable this feature.

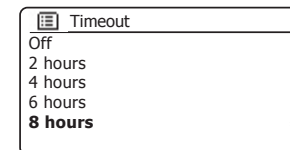
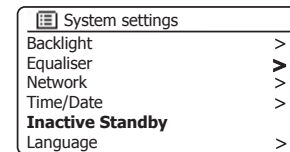

Note that if the sleep timer is used (see page 98) then the sleep timer will override this setting.

## Optical S/PDIF output socket

A digital output socket providing an S/PDIF signal is provided on the rear of your sound system for connection to an amplifier, mini-disc or other equipment with a digital optical input.

## Aerial removal

The fitted telescopic aerial is suitable for most applications. The telescopic aerial may be removed to allow connection to an external aerial using a coaxial cable.

First remove the two small screws holding the antenna connector cover in place (use a small cross-head screw driver). Then using the supplied spanner, remove the telescopic aerial by rotating in an anti-clockwise direction when viewed from the rear of the product.

This will expose an F-type connector to which an external aerial may be connected.

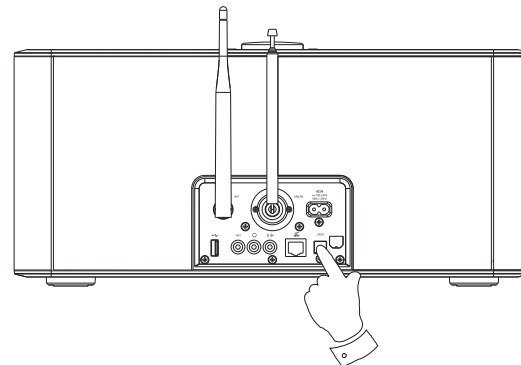

## Factory reset

If you wish to completely reset your sound system to its initial state this may be performed by following this procedure. By performing a factory reset, all user entered settings will be erased.

1. To access the menu for the current mode **press and hold** the **Menu** button. Press the **Menu Up** or **Down** buttons to highlight the 'Main menu' option, then press and release the **Select** button to select.
2. Press the **Menu Up** or **Down** buttons until 'System settings' is highlighted and then press and release the **Select** button to select.
3. Press the **Menu Up** or **Down** buttons until 'Factory reset' is highlighted and then press and release the **Select** button. Press the **Menu Up** or **Down** buttons and highlight 'YES' to proceed.  
If you do not wish to carry out a system reset, highlight 'NO' and then press and release the **Select** button. The display will revert to the previous menu.
4. With 'YES' highlighted, press and release the **Select** button. A full reset will be performed and the sound system will restart as if first plugged in. The DAB stations list together with any preset stations will be erased and your wireless network connection details will be lost. All configuration settings will be restored to their defaults, the clock and alarms will be reset.

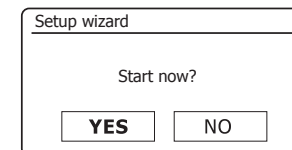
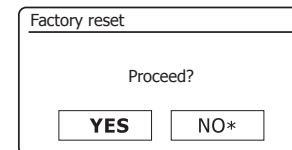
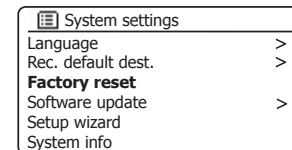
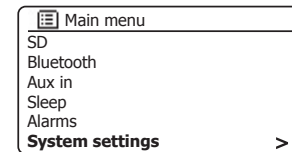
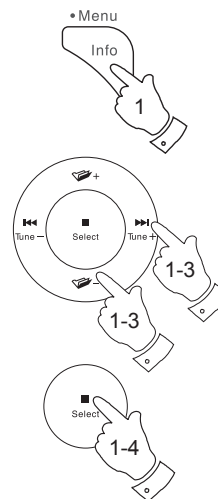

In case of malfunction for any reason, reset the product as described above to resume normal operation. It may be necessary in some cases to disconnect the mains power, then reconnect power after 10 seconds.

In case of malfunction due to electrical fast transient (burst), reset the product as above (reconnection of the power source may be required) to resume normal operation.

When connecting the sound system to a router with an Ethernet cable, shielded cable is highly recommended. The communication could be interrupted temporarily or noise may occur if using un-shielded cable and under strong local interference (between 43 and 80MHz). Normal communication will resume automatically when the interference signal is removed. FM radio reception may also benefit from the use of a shielded cable.

## Software update

From time to time, new software features for your sound system may be developed. Your sound system has therefore been designed to allow its internal software to be updated using your Internet connection.

You should not attempt to update your sound system unless it is recommended to you by Roberts Customer Services. Updating the software may remove all network settings, radio station presets and alarm settings from your sound system.

It is important that you do not attempt this procedure unless you have a good Internet connection and a reliable mains power supply. If the radio connects to your router using a WiFi connection, make sure that this is also reliable before proceeding.

1. The '*Software update*' option is accessed via the System Settings menu. When you select '*Software update*' the menu will display '*Auto check setting*' and '*Check now*'. If you want your sound system to check periodically for new software versions press the **Menu Up** or **Down** buttons to highlight '*Auto check settings*'. Then press and release the **Select** button and select '*YES*'. If you do not want your sound system to check for updates select the '*NO*' option.
2. To check if there are any software updates available currently, press the **Menu Up** or **Down** buttons to highlight '*Check now*' and then press and release the **Select** button. The sound system will check to see if an update is available. The display will show '*Checking for new versions*'. If there are no updates then the display will show '*Software up to date*'. If a software update is available your sound system will then offer the choice of updating the software or not, displaying '*New version available. Update software?*'. Select the '*YES*' option if you wish to go through the update process.
3. If you choose to update your sound system it will first download the new software and will then reprogram its internal memory. This may take anything from a few seconds to a few minutes depending on the speed of your internet connection.
4. Once the software update is completed, the sound system will prompt you to press **Select** to restart. Press and release the **Select** button and your sound system will then restart. You may find that you will need to reconfigure your network connection following an update. You may also need to re-enter all radio station presets, alarm settings, and configuration options.

**VERY IMPORTANT:** Do not switch off the power to the sound system until the update operation is complete and the sound system has restarted, otherwise the unit may become permanently damaged.

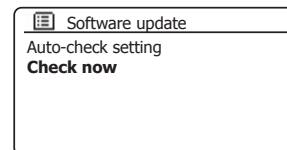
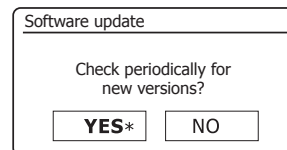
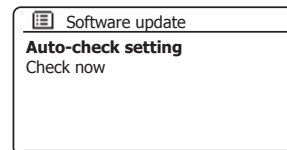
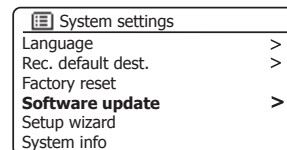
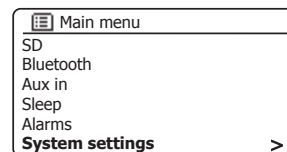



## Network profiles

Each time that you connect your sound system to a WiFi network, the sound system will store the details of that connection (SSID, security key, DHCP/IP address settings) as a profile. Up to four such profiles are stored in the sound system so that if the unit is used in multiple locations there is no need to enter the network settings when returning to a location previously visited.

The sound system stores the four most recent profiles in memory identified by their SSID. Normally the sound system will attempt to connect to one of the stored profiles and only if it is unable to do so will you need to use the Network Wizard (see page 17).

In the event that you visit a location only once you may wish to delete the profile for the network in that location to avoid losing other profiles.

1. To access the menu for the current mode **press and hold** the **Menu** button. Press the **Menu Up** or **Down** buttons until 'System settings' is highlighted on the display. Press and release the **Select** button to enter the System Settings menu.
2. Press the **Menu Up** or **Down** buttons until 'Network' is highlighted on the display. Press and release the **Select** button to enter the Network Settings menu.
3. Press the **Menu Up** or **Down** buttons until 'Network profile' is highlighted on the display. Press and release the **Select** button to see the stored profiles. The profile which is currently in use (if any) is marked with an asterisk.
4. To remove a profile from memory, press the **Menu Up** or **Down** buttons to highlight the profile to be deleted and then press and release the **Select** button.
5. The sound system will offer a 'YES' or 'NO' selection. Press the **Menu Up** or **Down** buttons to select 'YES' and then press and release the **Select** button. The selected profile will be deleted.

**Note:** It is not possible to delete a profile which is currently in use.

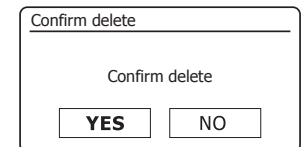
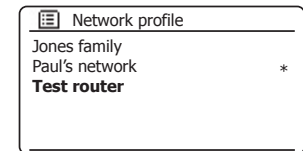
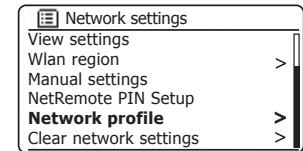
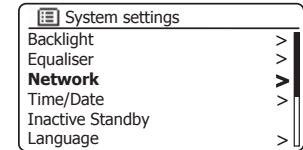
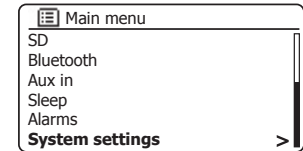
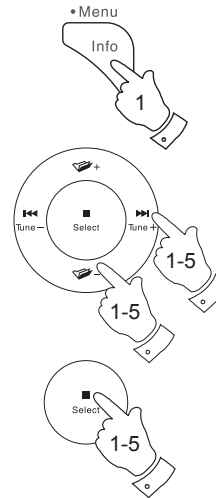

## Clear network settings

In the event that you pass your sound system on to someone else you may wish to remove all the network settings stored. This function will clear all stored network settings from your sound system.

1. Access the menu for the current mode, **press and hold** the **Menu** button. Press the **Menu Up** or **Down** buttons until 'System settings' is highlighted on the display. Press and release the **Select** button to enter the settings menu.
2. Press the **Menu Up** or **Down** buttons until 'Network' is highlighted on the display. Press and release the **Select** button to enter the **Network settings** menu.
3. Press the **Menu Up** or **Down** buttons until 'Clear network settings' is highlighted on the display. Press and release the **Select** button.
4. The sound system will offer a 'YES' or 'NO' selection. Press the **Menu Up** or **Down** buttons to select 'YES' and then press and release the **Select** button. The network settings will be deleted.
5. If you do not wish to clear the network settings, highlight 'NO' and then press and release the **Select** button. The display will revert to the previous menu.

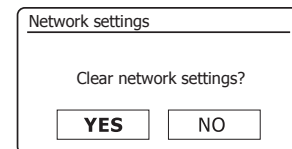
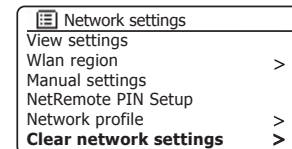
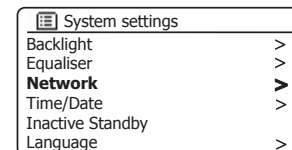
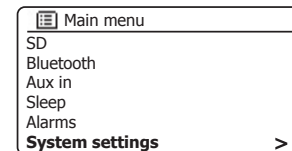
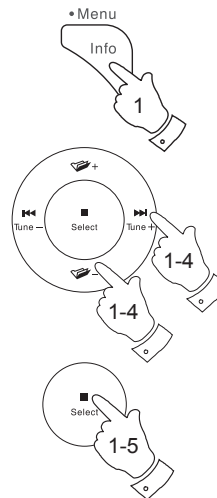

## Manual network configuration

If you do not wish to use DHCP for automatic network configuration, or if your network is configured with a hidden SSID, then you will need to enter some network settings manually. The typical user will not need to use manual network configuration. The facility is provided to allow the product to be used with networks where the configuration of devices is not managed by the router, or where customised settings may be required. In such cases it is assumed that the user already has sufficient knowledge to understand the terms and settings used for this purpose. IPv4 address schemes are used.

- From the sound system's Network Settings menu, select '*Manual settings*'. You must then choose whether to connect using '*Wired*' or '*Wireless*' connections. If you choose '*Wireless*' there are as many as nine settings screens, shown by the '*1 of 9*' progress marker in the top right corner of the display. If you choose '*Wired*' there are five screens and the progress marker will reflect this, although the steps to set up the network parameters are basically the same.
- The subsequent menus allow configuration of the following parameters:
  - DHCP - On or Off
  - IP address - e.g. 129.168.1.25
  - Subnet mask - e.g. 255.255.255.0
  - Gateway address - e.g. 129.168.1.1
  - DNS address (primary and secondary addresses)
  - SSID - needed for WiFi connections if the SSID is not broadcast
  - WEP / WPA / WPA2 key and settings

When entering numbers, the SSID or the WiFi pass key, the three controls on the right-hand side of the screen have special functions. You can quickly access these by pressing the **Info** button and then use the **Menu Up** or **Down** and the **Select** buttons as needed:

select '**BR5P**' to erase a character just entered (long press to clear); **Info** again to continue

select '**OR**' when the complete encryption key has been entered

select '**CANCEL**' to cancel and go back to the TKIP / AES options screen

- Upon completion of the settings the sound system should connect to the network. If the connection is made successfully, the sound system will return to the Network Settings menu. If the unit cannot connect, then it will display a '*Failed to connect*' message. You will then need to identify which setting may need to be changed, or whether some other network issue is responsible. Once connected, the network settings are saved. They are retained in memory while the sound system is disconnected from the mains.

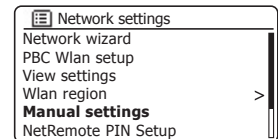
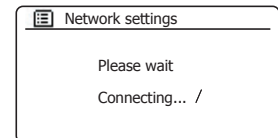
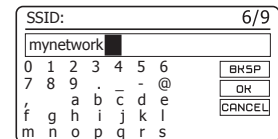
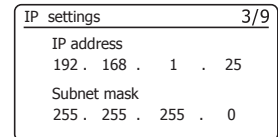
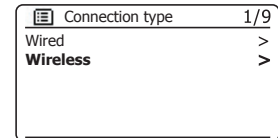
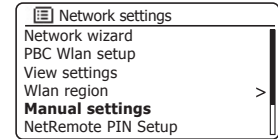

## Software version display

The software version display is provided for reference and customer support purposes.

1. To access the menu for the current mode **press and hold** the **Menu** button. Press the **Menu Up** or **Down** buttons until 'System settings' is highlighted on the display. Press and release the **Select** button to enter the System Settings menu.
2. Press the **Menu Up** or **Down** buttons until 'System Info' is highlighted on the display. Press and release the **Select** button to display the software version and radio ID. Press the **Menu Up** or **Down** buttons to display further information.
3. Press the **Menu** button to exit.

## Audio FAQ

Your sound system can access some audio help for Internet Radio use.

1. With your sound system switched on and in the **Internet Radio** mode, **press and hold** the **Menu** button. Press the **Menu Up** or **Down** buttons until 'Station list' is highlighted on the display. Press and release the **Select** button.
2. Press the **Menu Up** or **Down** buttons until 'Help' is highlighted on the display. Press and release the **Select** button to enter the Help menu.
3. Press the **Menu Up** or **Down** buttons until 'FAQ' is highlighted. Press and release the **Select** button to display some frequently asked questions.
4. Press the **Menu Up** or **Down** buttons to choose a question that suits your requirements and press and release the **Select** button to listen to the answer.  
Adjust the volume as needed.

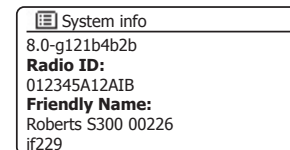
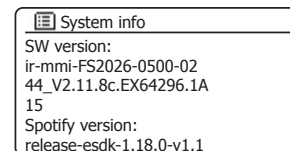
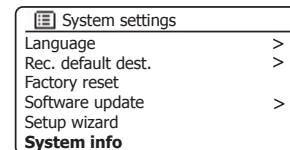
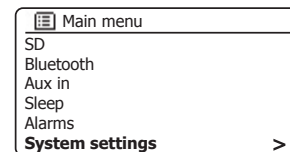
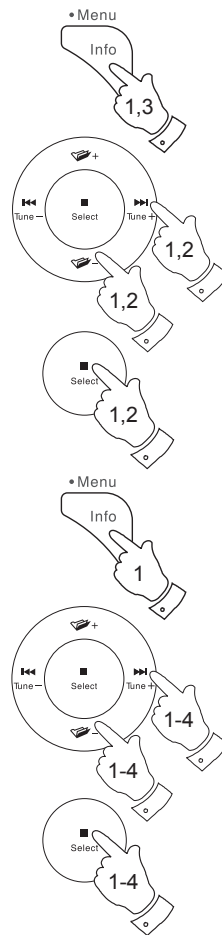

## Troubleshooting

If you experience any trouble with your sound system, then you may find it useful to visit the help section on our web site.

As a first step, the following points should be checked.

### Is there power to the sound system?

- Make sure your product is plugged in and connected to the mains - see page 10.
- Ensure your product is switched on.

### Is your sound system not receiving audio?

- Check the volume level of your product.
- Check your product is in range and that you have connected your product to your network.
- Ensure the product and the device used for control is connected to the **same** network.
- Ensure that WiFi is enabled on your device. Refer to your device's documentation for details.
- If your product is not visible within UNDOK, first try restarting the UNDOK app on your device. Try reinstalling the UNDOK app and check that you have the latest version installed.
- If the WiFi connection to the product appears unreliable, try relocating the WiFi antenna using the WiFi antenna base (see page 6) or try an Ethernet connection to verify the functioning of the product.
- Try to eliminate possible interference from other sources e.g. cordless phone, microwave oven etc.

If you have difficulty connecting the sound system to your computer network, some of these steps may help to resolve the problem:

1. Confirm that a WiFi connected PC can access the Internet (i.e. can browse the web) using the same network.
2. Check that a DHCP server is available (normally a router function). Your sound system will by default use DHCP unless you choose to disable it. This may be configured using the menu items '*Main Menu*' -> '*System settings*' -> '*Network*' -> '*Manual settings*'. This will ask first whether you wish to configure a wired or a wireless connection. For either wired or wireless you then need to choose '*DHCP enable*' or '*DHCP disable*'. If you enable DHCP then the sound system will negotiate with your router (or DHCP server) and will be provided with an IP address as well as the other settings needed. If you wish to set the network configuration manually, refer to paragraph 6.
3. Check that your network's firewall is not blocking any outgoing ports. As a minimum, the sound system needs access to UDP and TCP ports 80 and 123. Port 53 may be required for DNS. Some Internet radio services may require additional ports to be open. Windows Media Player 12 will allocate a port number for UPnP media sharing and will configure Microsoft's Windows built-in firewall appropriately. Other firewall software may require configuration for UPnP or to allow particular IP addresses to have trusted access.
4. Check that your access point does not restrict connections to particular MAC addresses (sometimes called MAC address filtering).  
You can view the radio's MAC address using the menu items '*Main Menu*' -> '*System settings*' -> '*Network*' -> '*View settings*' -> '*MAC address*'. The MAC address will typically be of the form  
**00 : 22 : 61 : xx : xx : xx**
5. If you have an encrypted network, check that you have entered the correct encryption key into the sound system. Remember that text-format WPA keys are case sensitive. If your sound system displays '*Network error*' when attempting to connect to an encrypted network, then please ensure that you enter the correct key for the network. If the problem persists, then you may need to re-check your network configuration.

## Troubleshooting cont.

6. If you need to set up your sound system's IP address manually, you will need to know low-level details of your network's configuration. Use the menu items '*Main Menu*' -> '*System settings*' -> '*Network*' -> '*Manual settings*' -> '*Wired*' or '*Wireless*' (as needed) -> '*DHCP disable*'.

The sound system will then prompt you in turn for the Ethernet IP address, Ethernet Subnet mask, Ethernet Gateway address, Ethernet Primary DNS, Ethernet Secondary DNS

If you are setting up a wireless connection manually you will also need to enter the SSID, the encryption type, and the encryption key.

See page 120 for full details on how to set up your sound system's network configuration manually.

If your sound system can connect to the network, but is unable to play a particular Internet radio station, it may be due to one these causes:

1. The station is not broadcasting at this time of the day.
2. The station has reached its maximum allowed number of simultaneous connections.
3. The Internet connection between your sound system and the server (often located in a different country) is slow. This could be due to internet congestion, either locally or at a distance.
4. The station may choose to block internet connections to your geographic region (sometimes known as geo-locking).
5. The station is no longer broadcasting. The database of radio stations that your radio connects to is frequently updated and checked but may not always be completely accurate.
6. The radio station is broadcasting using an audio format which is not playable by your sound system (although the S300 does play the most popular formats used by regular broadcasters).

Try using a PC to listen via the broadcaster's web site or via the radio station database web site at <http://www.wifiradio-frontier.com>. If you can play the station with a PC, it may be that the internet feed or local network connection is poor. However, some broadcasters (such as the BBC) provide different data streams for PC users and Internet radio listeners, so this test is not always conclusive.

If you cannot play the station via your PC this may indicate that the problem is not necessarily due to your sound system, but it could be your network, your internet connection, the broadcaster, or internet congestion.

## Music Player / UPnP problems

The use of the Music Player function with UPnP should be straightforward. However, the cleverness of UPnP means that it is often disabled by default by security applications and in routers.

If you are using Windows Media Player as your UPnP server, and if it fails to operate with your sound system, please keep this fact in mind: *A fresh installation of Windows and Windows Media Player when using Microsoft's built-in firewall software will normally work.*

If it does not work, possible reasons may include:

UPnP functions blocked in firewall software

UPnP functions turned off by security software

UPnP functions 'hi-jacked' by other software

UPnP functions blocked in the router

Multi-cast packets blocked in the router

IP address of system blocked in firewall software

Some third-party UPnP servers are much less dependent upon other parts of Windows than WMP 12. If the greater flexibility that these offer is attractive, it may also be found in some cases that they are easier to get working.

## Audio codecs

Your sound system supports a range of audio codecs which provide compatibility with a wide range of Internet Radio stations. These also allow users to stream music from their computers or to play directly from USB and SD/SDHC flash memory devices.

Note that for any given audio codec, there are many streaming protocols available, and thus even if an Internet Radio station uses a supported format, this does not guarantee that every such station will work with your sound system. The radio stations database to which your sound system connects is checked for compatibility so that most stations should be playable without problems. Similarly when streaming media from a computer, while a codec may be supported, there can be many subtle variations in formats, tagging schemes and protocols (even within UPnP). In general your sound system will play the supported formats with most common UPnP servers.

The following table summarises the maximum supported bit-rates for the various audio formats that are playable on your sound system. Higher rates may be playable in some cases but performance of the product may be affected.

<b>Codec</b>	<b>Maximum supported data rate</b>
AAC (LC, HE, HE V2)	320 kbits/sec
ALAC <sup>(1)</sup> <sup>(5)</sup>	1.5 Mbits/sec
FLAC <sup>(2)</sup> <sup>(5)</sup>	1.5 Mbits/sec
LPCM <sup>(3)</sup>	1.536 Mbits/sec
MP3	320 kbits/sec
WAV <sup>(3)</sup>	1.536 Mbits/sec
WMA <sup>(4)</sup>	320 kbits/sec

All codecs support 2-channel (stereo) coded files only.

All codecs support sample rates up to 48 k samples/sec (includes 32 k and 44.1 k samples/sec).

USB and SD/SDHC playback supports MP3 and WMA formats only.

Files which have Digital Rights Management (DRM) protection applied will not be playable on your sound system.

(1) 16 bit samples are supported in ALAC files.

(2) 16 and 24 bit samples are supported in FLAC files.

(3) The maximum supported bit-rate is for 48 kHz sampling, 2 channels and 16-bits per sample.

(4) WMA Lossless, WMA Voice, WMA 10 Professional, and files which have DRM protection are not supported.

(5) When using your sound system as part of a group of multi-room products, audio files in ALAC and FLAC formats will only play on the group master (see page 51).

## Cautions

### Safety instructions

- There are no user serviceable parts inside this product.
- Do not attempt to open or disassemble any part of the product.
- Do not dispose of the product in a fire or incinerator.
- Do not expose the product to water, moisture, steam or sand.
- Use only the mains power lead supplied with the product or a genuine replacement provided by Roberts Radio.
- The mains plug or multi-way mains block is used as the disconnect device. The disconnect device shall remain readily operable.
- To maintain the compliance with the WiFi RF exposure requirement, place the product at least 20 cm (8 inches) from nearby persons except when operating the controls.
- The mains lead and sound system shall not be exposed to dripping or splashing and no objects filled with liquids, such as vases, shall be placed on the mains lead or the sound system.

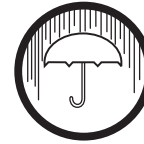

Do not leave your sound system where excessive heat could cause damage.

- Avoid using or storing the product at extremes of temperature. Avoid leaving the unit in cars, on window sills, in direct sunlight etc.
- The sound system must be used in a moderate climate.
- No naked flame sources such as lighted candles should be placed on the product.
- It is recommended to operate the product such that there is a minimum distance (10cm recommended) to adjacent objects in order to ensure good ventilation.
- The ventilation of the product should not be restricted by covering it with items such as newspapers, tablecloths, curtains etc.





## Specifications

### Power Requirements

Mains	100 - 240 volts AC, 50Hz/60Hz
Remote Control Battery	2 x CR2032

### Connectivity

Wired Ethernet	10/100M bits/sec via RJ-45 connector
WiFi	802.11 b, g, n, a supported with WEP and WPA / WPA2 encryption

Compatible with 2.4 GHz and 5 GHz WiFi bands

Bluetooth standards	A2DP, AVRCP
Bluetooth codecs supported	SBC and AAC

### Frequency Coverage

FM	87.5 - 108MHz
DAB	174.928 - 239.200MHz

The name plate is located underneath the sound system.

The Company reserves the right to amend the specification without notice.

## Circuit features

Headphone socket	3.5mm diameter, stereo
Aux In socket	3.5mm diameter, stereo
Line out socket	3.5mm diameter, stereo
Digital optical output socket	Toslink

Aerial System	WiFi	WiFi antenna
	DAB	Telescopic aerial
	FM	Telescopic aerial

## Information

## Mains supply

The S300 will operate from a supply of 100-240V ~ 50/60Hz.

**DO NOT cut off the mains plug from this equipment.** If the plug fitted is not suitable for the power points in your home or the cable is too short to reach a power point, then obtain an appropriate safety approved extension lead or adaptor. If in doubt consult your dealer.

If nonetheless the mains plug is cut off, remove the fuse and dispose of the plug immediately to avoid a possible shock hazard by inadvertent connection to the mains supply.

If this product is not supplied with a mains plug, or one has to be fitted, then follow the instructions given below:

**IMPORTANT. DO NOT** make any connection to the larger terminal which is marked with the letter E or by the safety earth symbol  or coloured Green or Green-and-yellow.

The wires in the mains lead are coloured in accordance with the following codes :-

BLUE - NEUTRAL

BROWN - LIVE

The wire coloured BLUE must be connected to the terminal marked N or coloured BLACK.

The wire coloured BROWN must be connected to the terminal marked L or coloured RED.

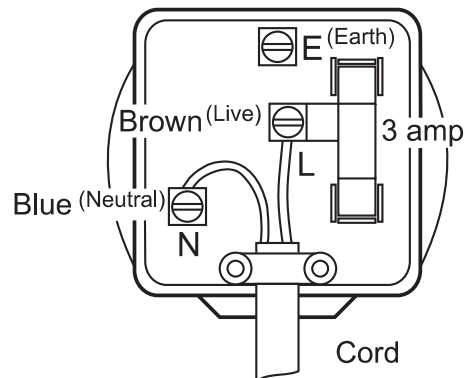

## Fuse

When replacing the fuse only a 3A ASTA approved to BS1362 type should be used and be sure to re-fit the fuse cover.

IF IN DOUBT - CONSULT A QUALIFIED ELECTRICIAN.

Use of the software in this product is subject to software licence terms contained in this user manual - by using the product, you are agreeing to comply with these licence terms:

**Thompson Licensing: MP3 audio decoder**

MPEG Layer-3 audio coding technology licensed from Fraunhofer IIS and Thomson

**Fraunhofer: MPEG-4 HE AAC Audio decoder**

MPEG-4 HE-AAC audio coding technology licensed by Fraunhofer IIS:

<http://www.iis.fraunhofer.de/amm/>

**Microsoft: Windows Media Audio decoder (WMA)**

This product is protected by certain intellectual property rights of Microsoft. Use or distribution of such technology outside of this product is prohibited without a license from Microsoft.

**Microsoft: Real Time Streaming Protocol (RTSP)**

This product is protected by certain intellectual property rights of Microsoft. Use or distribution of such technology outside of this product is prohibited without a license from Microsoft.

**Spotify: Spotify Connect**

The Spotify software is subject to third party licenses found here:

<http://www.spotify.com/connect/third-party-licenses>

**Updates**

If you download a software upgrade to your product, additional licence terms may apply and these are available at:

<http://www.frontier-silicon.com/audio/eula.htm>

## Guarantee

This product is guaranteed for twenty four months from the date of purchase by the original owner against failure due to faulty workmanship or component breakdown, subject to the procedure stated below. Should any component or part fail during this guarantee period it will be repaired or replaced free of charge.

The guarantee does not cover:

1. Damage resulting from incorrect use.
2. Consequential damage.
3. Product with removed or defaced serial numbers.

N.B. Damaged or broken aerials will not be replaced under guarantee.

Procedure:

Any claim under this guarantee should be made through the dealer from whom the product was purchased. It is likely that your Roberts' dealer will be able to attend to any defect quickly and efficiently, but should it be necessary the dealer will return the product to the company's service department for attention. In the event that it is not possible to return the product to the Roberts dealer from whom it was purchased, please contact Roberts Radio using the contact details on the [www.robertsradio.com](http://www.robertsradio.com) website.

For product repairs falling outside the guarantee period, please refer to the "Customer care" tab on the [www.robertsradio.com](http://www.robertsradio.com) website.

*These statements do not affect the statutory rights of a consumer.*

### ROBERTS RADIO LIMITED

PO Box 130  
Mexborough  
South Yorkshire  
S64 8YT



Website: <http://www.robertsradio.com>

